

APPROVAL

DESCRIPTION : TUN-CAP 40-160P 20 × 20A

NCE PARTS NO. : IE443AB01-A04

PARTS NO. :

DRAWING :

RECEIVED

VENDOR:NEWCONT ELE.CO.,LTD.

ADD: 40 Floor, Block C Electronics Science & Technology

Building Shennanzhonglu, Shenzhen,Guangdong,P.R.China

TEL:86-755-3274500

FAX:86-755-3274577

[Http://www.newcont.com](http://www.newcont.com)

E-mail:pvc@newcont.com

NCE

POLYVARICON

MODEL: IE443AB01-A04

**新大陆电子有限公司
NEWCONT ELE. CO., LTD.**

**地址：中国、广东、深圳市深南中路 2070 号电子科技大厦
C 座 40 层**

**ADD: 40 Floor, Block C Electronics Science & Technology
Building Shennanzhonglu, Shenzhen, Guangdong, P.R. China**

TEL: 86-755-3274500

FAX: 86-755-3274577

[Http://www.newcont.com](http://www.newcont.com)

E-mail: pvc@newcont.com

Outline drawing

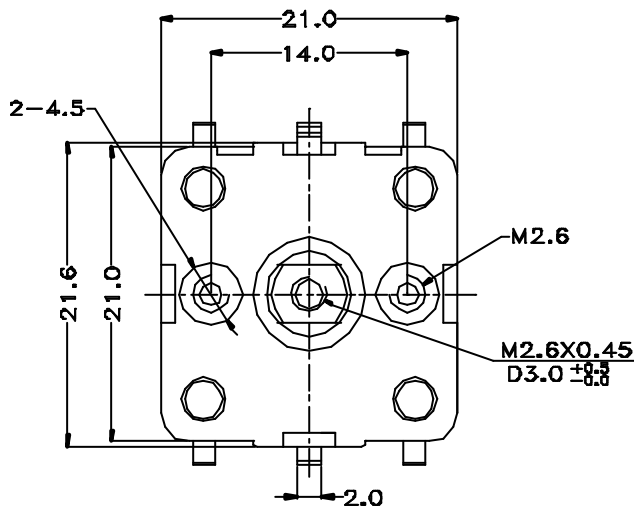
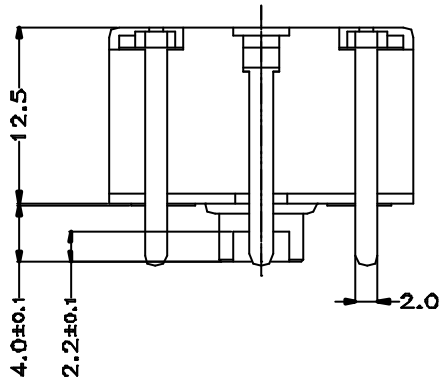
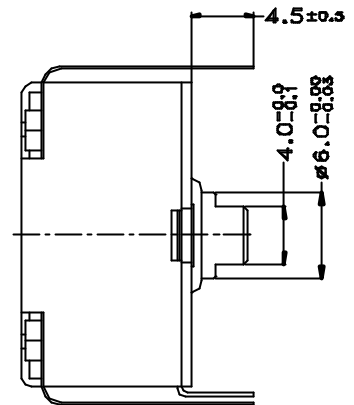
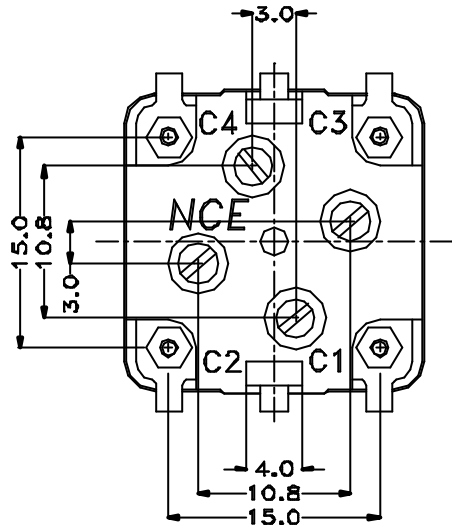

- C1: FM OSC**
- C2: FM ANT**
- C3: AM OSC**
- C4: AM ANT**

REVISIONS	APPEARANCE		MODEL
	UNIT: mm	SCALE: 2/1	IF443AB01-A04
	DIMENSION TOLERANCE GENERAL ± 0.3		CODE NUMBER
	DESIGNED BY: WISDOM TIAN		190-01-01
	DRAWN BY: WISDOM TIAN		NCE
	CHECKED BY: WISDOM TIAN		
	APPROVED BY: L.K.ZHANG		

1. Application

This specification is applicable for 4 gangs capacitor , model **IE443AB01-A04** with 2 gangs of equal capacitance on AM section and with 2 gangs of equal capacitance on FM section, for tuned 520-1650 kHz and oscillation circuit 455 kHz of transistor radio.

2. Electrical Characteristics

2-1. Capacitance

Effective capacitance at each position is shown on Table 1 , defining the rotation angle 180 ° is expressed 100%.

Table 1 Capacitance & Coefficient

A M			F M		
Rotation	OSC / ANT		OSC / ANT		Rotation
(%)	Coef.	Capa.(pF)	Coef.	Capa.(pF)	(%)
*100	100.00	160.00	100.00	40.00	*100
90	84.40	135.04	86.18	34.47	90
*82.9	72.72	116.35	73.37	29.35	80
75	60.00	96.00	67.32	26.93	*75
70	52.30	83.68	61.48	24.59	70
*59	36.66	58.66	50.42	20.17	60
50	26.20	41.92	40.12	16.05	*50
*43.5	19.98	31.97	30.50	12.20	40
30	10.20	16.32	21.52	8.61	30
*28.4	9.29	14.86	17.25	6.90	*25
20	5.31	8.50	13.11	5.24	20
*15.4	3.50	5.60	5.23	2.09	*10
3	0.00	0.00	0.00	0.00	3

2-2. Minimum Capacitance

Minimum Capacitance shown on Table 2 is defined at the end stop, where shaft is rotated full clockwise. But trimmer capacitance is minimum.

Table 2

Section	Minimum Capacitance
AM	C3 : 4.0± 1.0 pF , C4 : 4.2 ± 1.0pF
FM	C1 : 3.8 ± 1.0pF , C2 : 3.6 ± 1.0pF

2-3. Tolerance of Capacitance

The tolerance of the effective capacitance is shown Table 3

Table 3

Condition	Section	Standard
At the angle of ? marking of Table 1	OSC	AM ± (1.5% + 1.5 pF) , FM ± (1.0 % + 1.0 pF)
	ANT	AM ± (1.5% + 1.5 pF) , FM ± (1.0 % + 1.0 pF)

Clause	Item	Condition	Standard
2 - 4	Insulation Resistance	At D.C. 100V	More than 100 M
2 - 5	Voltage Proof	Running D.C. 100V for 1 minute	Not to be found unusually
2 - 6	Q Characteristics	AM	Valued at 10MHz 50pF
		FM	Valued at 100MHz 10pF
2 - 7	Contact Resistance	Valued at the tops of shaft and earth terminals when 1kHz ± 200Hz and 100mA are supplied(Rotation speed 30 times/minute)	Less than 20 m

3. Mechanical Characteristics

Clause	Item	Condition	Standard
3 - 1	Direction of the rotation	Capacitance change when shaft is rotated clockwise	Decreasing
3 - 2	Shaft Rotation	Rotation range is defined 100% for 180 °	97% (+2 to -1%)
3 - 3	Rotation Torque	Torque application when shaft is rotated full at normal temperature condition	50 - 400 gf.cm
3 - 4	Strength of end stop	A specimen is left in the standard test condition for 1 minute after 5 kgf.cm rotations	Not to be found insulate both electrically and mechanically
3 - 5	Ratio of Max. and Min. torque	Max.: Min.	Within 3: 1

4. Trimmer ability

Clause	Item	Condition	Standard
4 - 1	Shaft Rotation	Rotation range	360 °
4 - 2	Rotation Torque	On the whole rotation range. Ratio of Max. and Min. torque	50 – 400 gf-cm Max.: Min. within 3 : 1
4 - 3	Effective Capacitance		More than 5 pF
4 - 4	Q Characteristics	At maximum capacitance and 10 MHz(main capacitance is minimum)	More than 200

5. Materials

5-1. Body Parts

Component	Materials
Base	Degeneration ABS included glass
Case	Degeneration PP or AS
Rotor Shaft	Brass
Rotor Plate	Aluminum or Brass
Stator Plate	Aluminum - Polyethylene film
Terminal	Iron or Brass - Tin plating

5-2. Trimmer Parts

Component	Materials
Trimmer Base	Degeneration ABS included glass
Trimmer Shaft	Brass or Copper Alloys
Trimmer Rotor Plate	IRON - Nickel plating
Trimmer Stator Plate	IRON - Polyethylene film

AM curve-IA

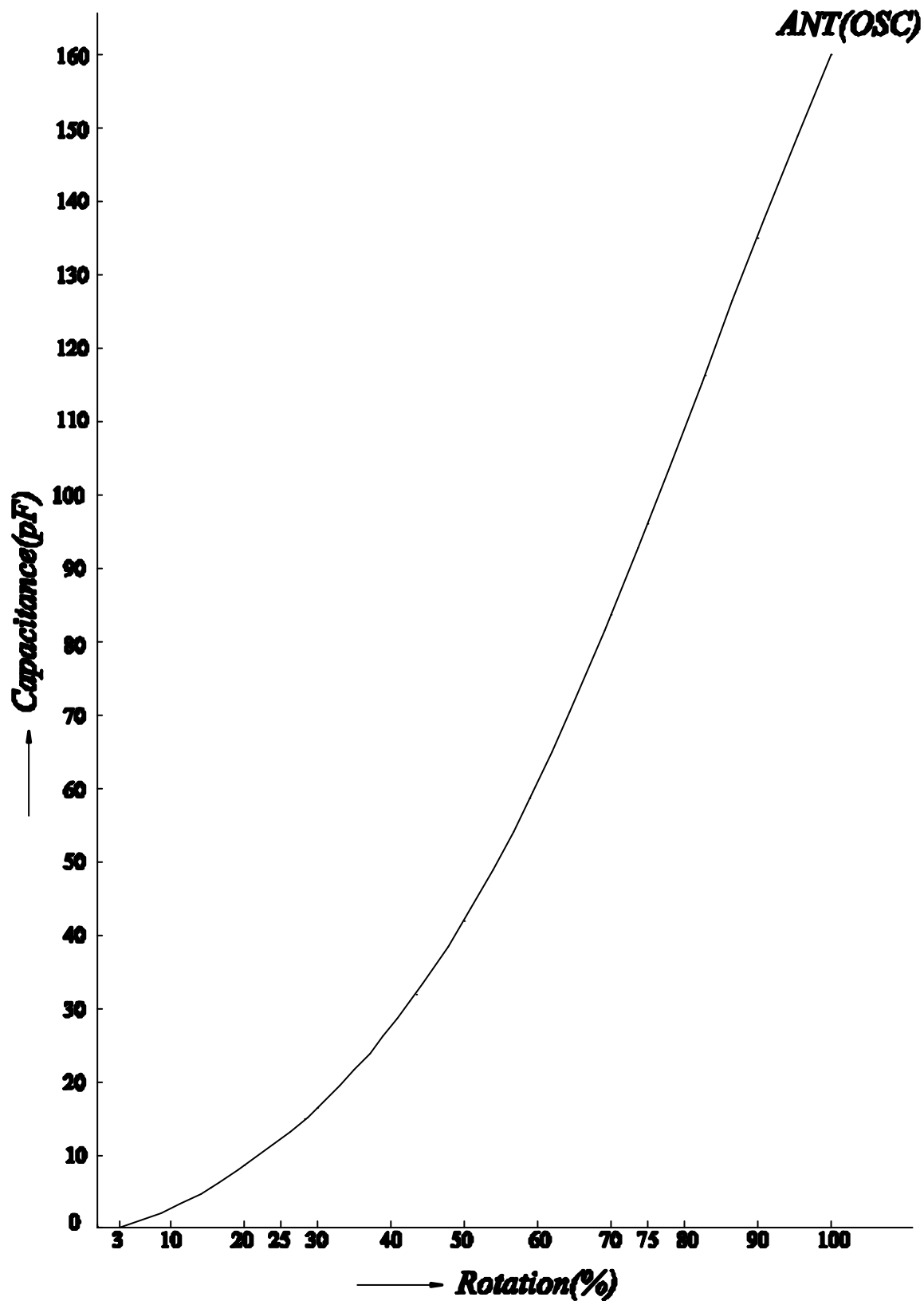

FM curve-EB

