

# APPROVAL

DESCRIPTION : TUN-CAP 20-335P 20 × 20A

NCE PARTS NO. : AF443AB93-A04

PARTS NO. :

DRAWING :

**RECEIVED**

**VENDOR:**NEWCONT ELE.CO.,LTD.

**ADD:** 40 Floor,Block C Electronics Science & Technology

Building Shennanzhonglu ,Shenzhen,Guangdong,P.R.China

**TEL:**86-755-83274500

**FAX:**86-755-83274577

**[Http://www.nce-newcont.com](http://www.nce-newcont.com)**

**E-mail:**[pvc@newcont.com](mailto:pvc@newcont.com)

# NCE

## POLYVARICON

**MODEL: AF443AB93-A04**

**新大陆电子有限公司**

**NEWCONT ELE. CO., LTD.**

---

地址：中国、广东、深圳市深南中路 2070 号电子科技大厦  
C 座 40 层

**ADD: 40 Floor, Block C Electronics Science & Technology**

**Building Shennanzhonglu, Shenzhen, Guangdong, P.R. China**

**TEL: 86-755-83274500**

**FAX: 86-755-83274577**

[Http://www.nce-newcont.com](http://www.nce-newcont.com)

**E-mail: [pvc@newcont.com](mailto:pvc@newcont.com)**

Outline drawing

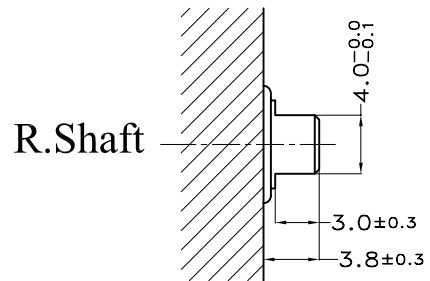
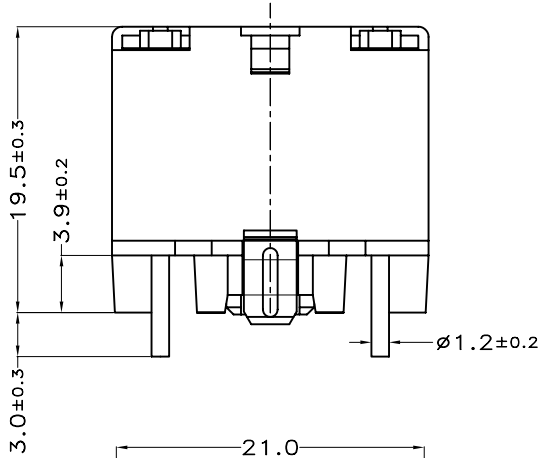
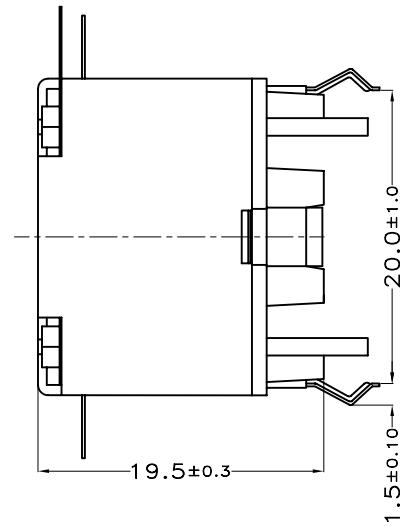
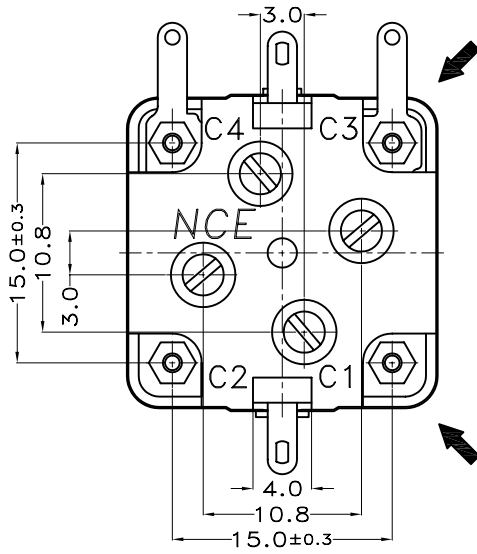

Mounting hole detail

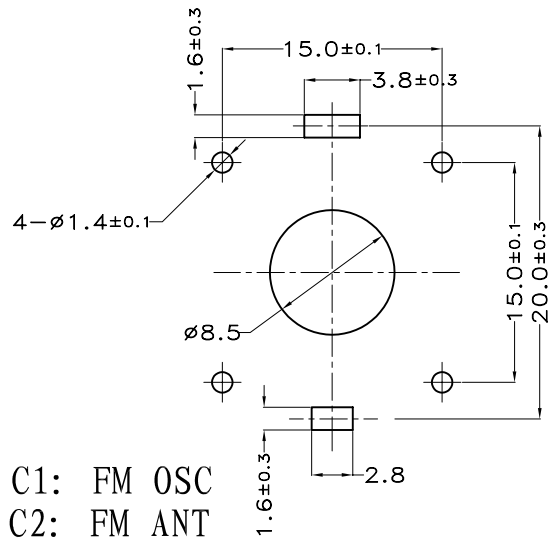
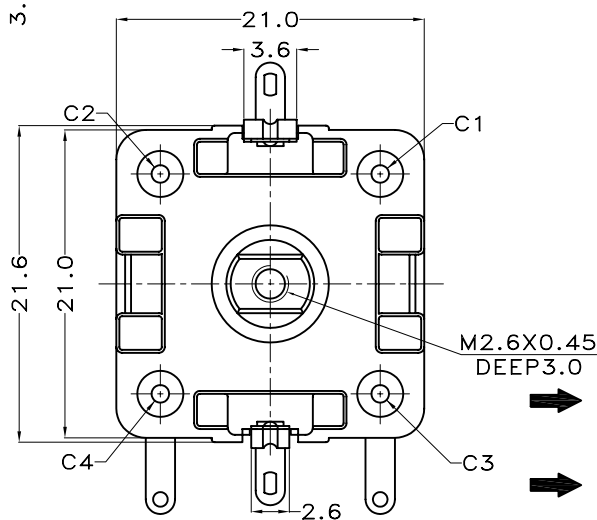

- ➔ C1: FM OSC
- ➔ C2: FM ANT
- ➔ C3: AM OSC
- ➔ C4: AM ANT

REVISIONS	APPEARANCE		MODEL
	UNIT: mm	SCALE: 2/1	AF443AB93-A04
	DIMENSION TOLERANCE		CODE NUMBER
	GENERAL ± 0.3		189-93-02
	DESIGNED BY:	WISDOM TIAN	<b>NCE</b>
	DRAWN BY:	WISDOM TIAN	
	CHECKED BY:	LASER YANG	
	APPROVED BY:	L.K.ZHANG	

**1. Application**

This specification is applicable for 4 gangs capacitor , model **AF443AB93-A04**with 2 gangs of equal capacitance on AM section and with 2 gangs of equal capacitance on FM section, for tuned 520-1650kHz and oscillation circuit 455kHz of transistor radio.

**2. Electrical Characteristics**

**2-1. Capacitance**

Effective capacitance at each position is shown on Table 1 , defining the rotation angle 180 ° is expressed 100%.

Table 1 Capacitance & Coefficient

A M			F M		
Rotation	OSC / ANT		OSC / ANT		Rotation
(%)	Coef.	Capa.(pF)	Coef.	Capa.(pF)	(%)
*100	100.00	335.00	100.00	20.00	*100
90	84.40	282.74	86.18	17.24	90
*80	67.90	227.47	73.37	14.67	80
75	60.00	201.00	67.32	13.46	*75
70	52.30	175.21	61.48	12.30	70
*60	38.00	127.30	50.42	10.08	60
50	26.20	87.77	40.12	8.02	*50
*40	17.00	56.95	30.50	6.10	40
30	10.20	34.17	21.52	4.30	30
*25	7.57	25.36	17.25	3.45	*25
20	5.31	17.79	13.11	2.62	20
*10	1.74	5.83	5.23	1.05	*10
3	0.00	0.00	0.00	0.00	3

**2-2. Minimum Capacitance**

Minimum Capacitance shown on Table 2 is defined at the end stop, where shaft is rotated full clockwise. But trimmer capacitance is minimum.

Table 2

Section	Minimum Capacitance
AM	C3 : 4.4 ± 1.0pF , C4 : 4.2 ± 1.0pF
FM	C1 : 3.0 ± 1.0pF , C2 : 4.0 ± 1.0pF

**2-3. Tolerance of Capacitance**

The tolerance of the effective capacitance is shown Table 3

Table 3

Condition	Section	Standard
At the angle of * marking of Table 1	OSC	AM ± ( 1.5% + 1.5 pF ) , FM ± ( 1.0 % + 1.0 pF )
	ANT	AM ± ( 1.5% + 1.5 pF ) , FM ± ( 1.0 % + 1.0 pF )

Clause	Item	Condition	Standard
2 - 4	Insulation Resistance	At D.C. 100V	More than 100 M
2 - 5	Voltage Proof	Running D.C. 100V for 1 minute	Not to be found unusually
2 - 6	Q Characteristics	AM	Valued at 10MHz 50pF
		FM	Valued at 100MHz 10pF
2 - 7	Contact Resistance	Valued at the tops of shaft and earth terminals when 1kHz ± 200Hz and 100mA are supplied(Rotation speed 30 times/minute)	Less than 20 m

**3. Mechanical Characteristics**

Clause	Item	Condition	Standard
3 - 1	Direction of the rotation	Capacitance change when shaft is rotated clockwise	Decreasing
3 - 2	Shaft Rotation	Rotation range is defined 100% for 180 °	97% (+2 to -1%)
3 - 3	Rotation Torque	Torque application when shaft is rotated full at normal temperature condition	50 - 400 gf.cm
3 - 4	Strength of end stop	A specimen is left in the standard test condition for 1 minute after 5 kgf.cm rotations	Not to be found insulate both electrically and mechanically
3 - 5	Ratio of Max. and Min. torque	Max.: Min.	Within 3: 1

**4. Trimmer ability**

Clause	Item	Condition	Standard
4 - 1	Shaft Rotation	Rotation range	360 °
4 - 2	Rotation Torque	On the whole rotation range. Ratio of Max. and Min. torque	50 – 400 gf-cm Max.: Min. within 3 : 1
4 - 3	Effective Capacitance		More than 5 pF
4 - 4	Q Characteristics	At maximum capacitance and 10 MHz(main capacitance is minimum)	More than 200

**5. Materials**

**5-1. Body Parts**

Component	Materials
Base	Degeneration PPO or PPE included glass
Case	Degeneration PP or AS
Rotor Shaft	Brass
Rotor Plate	Aluminum or Brass
Stator Plate	Aluminum - Polyethylene film
Terminal	Iron or Brass - Tin plating

**5-2. Trimmer Parts**

Component	Materials
Trimmer Base	Degeneration PPO or PPE included glass
Trimmer Shaft	Brass or Copper Alloys
Trimmer Rotor Plate	Brass - Nickel plating
Trimmer Stator Plate	Brass - Polypropylene film

**6. Specific Examinations**

Clause	Item	Condition	Standard
6 - 1	Vibration	By the vibration with frequency 10-55-10HZ/minute. 2.0mm to three directions of maximum capacitance for 2 hours.	Clattering or loosening shall not be occurred.
6 - 2	Load (at maximum capacitance)	Parallel load: 2kg weight is loaded to the shaft for 10 second and removing.	Satisfying clauses 2-4, 2-5, 2-6, 2-7 and 3-3.
		Perpendicular load: 1kg weight is loaded to the shaft for 10 second	
6 - 3	Impact	By letting a specimen fall down from the height of 50 cm three times to a wooden board, or by giving impact of 80 grams to 6 faces of the specimen on time each.	Capacitance drift within $\pm 2\%$ or $\pm 0.5\text{pF}$ against initial value at maximum effective capacitance.
6 - 4	Rotation Life	By 10000 rotations with 10-15 rotations per minute $80\pm 5\%$ rotation range.	
6 - 5	Heat Endurance	A specimen is kept in a chamber with constant temperature $70\pm 2$ for 16 hours and left in the standard test condition for one or two hours.	Satisfying clauses 2-4 , 2-6 , 4-2 , 4-3 and 4-4
6 - 6	Cold Endurance	A specimen is kept in a chamber with constant temperature $-20\pm 2$ for 16 hours and left in the standard test condition for one or two hours.	
6 - 7	Soldering (Terminals)	The end part 2mm of the terminal are given temperature $270\pm 5$ for $2\pm 0.5$ seconds.	Satisfying clauses 2-4, 2-5, 2-6, 2-7, 3 and 4.

**6-8. Temperature Cycles**

A specimen at maximum capacitance is kept in the chamber (one is cold, another is hot) with constant temperature and humidity in every stage on table 4 and left in the standard test condition for 1 hour, clattering or loosening shall not be occurred. Satisfying clauses 2-4, 2-6, and 3-3. Maximum capacitance variation rate : within 2.0%

Table 4

Stage	1	2	3	4	5	6	7	8
Temperature $\pm 2$	-20	70	-20	70	-20	70	-20	70
Time ( Hour )	1	1	1	1	1	1	1	1

**6-9. Humidity Endurance**

A specimen is kept in a chamber with temperature  $40\pm 2$  and relative humidity 90% to 95% for 96 hours. And after leaving in the standard test condition for one or two hours. The specimen is valued, and the results shall satisfy table 5.

Table 5

		AM side	FM side
Insulation Resistance		More than 50 M ( D.C. 100V )	
Q	Body	More than 500 ( 10MHz 50pF)	More than 150 (100MHz 10pF)
Characteristics	Trimmer	More than 150 ( 10 MHz Cmax )	
Maximum Capacitance Drift		Within $\pm 2\%$	

The standard test condition

This means the condition of temperature 5 to 35 and relative humidity 45 to 85% , but that of  $20\pm 2$  and  $65\pm 5\%$  if there is any doubt.

# AM curve-AA

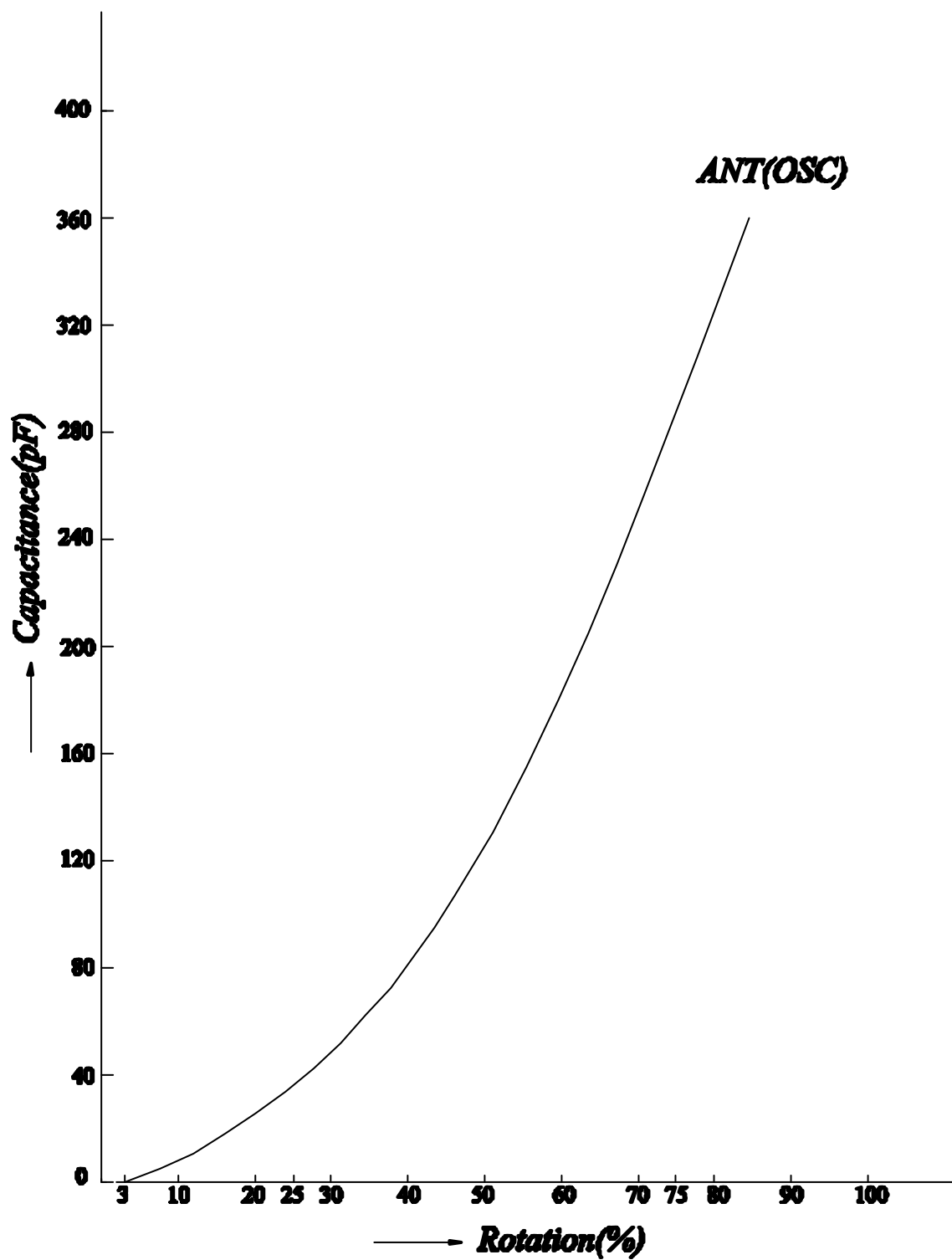

# FM curve-FB

