

APPROVAL

DESCRIPTION : TUN-CAP 20P-160P 20×20A

NCE PARTS NO. : JF443WAB04-A04

PARTS NO. :

DRAWING :

RECEIVED

VENDOR:UNITY SYSTEM.CO.,LTD.

ADD: 17Floor,Block west QIUSHI Building ,zhuzilinlu,
Shennandadao ,Shenzhen,Guangdong,P.R.China

TEL:86-755-88316650

FAX:86-755-88316651

[Http://www.newcont.com](http://www.newcont.com)

E-mail:pvc@newcont.com

NCE

POLYVARICON

MODEL: JF443WAB04-A04

UNITY SYSTEM. CO., LTD.

**ADD: 17Floor,Block west QIUSHI Building,zhuzilinlu,
Shennandadao ,Shenzhen,Guangdong,P.R.China**

TEL:86-755-88316650

FAX:86-755-88316651

[Http://www.newcont.com](http://www.newcont.com)

E-mail:pvc@newcont.com

Outline drawing

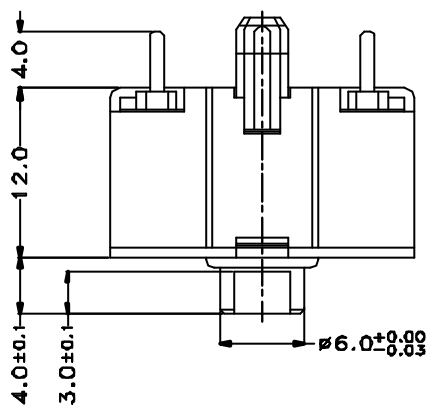
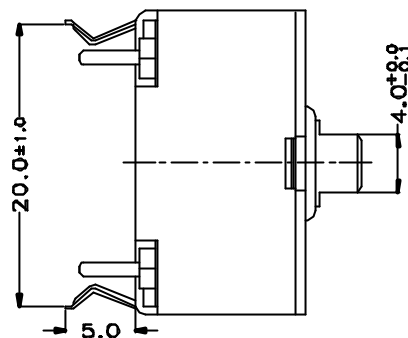
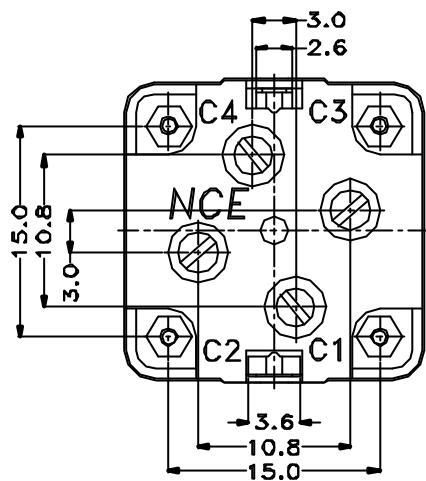

Mounting hole detail

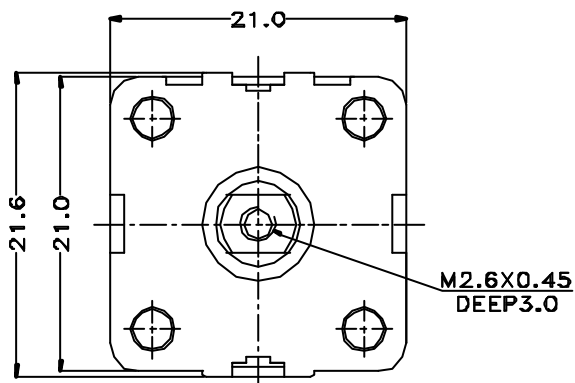
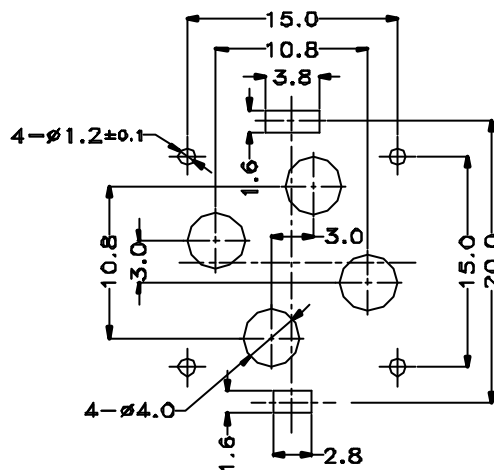

- C1: FM OSC**
- C2: FM ANT**
- C3: AM OSC**
- C4: AM ANT**

REVISIONS	APPEARANCE		MODEL
	UNIT: mm	SCALE: 2/1	JF443WAB04-A04
	DIMENSION TOLERANCE GENERAL ± 0.3		CODE NUMBER
	DESIGNED BY: WISDOM TIAN		190-04-04
	DRAWN BY: WISDOM TIAN		NCE
	CHECKED BY: LASER YANG		
	APPROVED BY: L.K.ZHANG		

1. Application

This specification is applicable for 4 gangs capacitor , Model JF443WAB04-A04 with 2 gangs of different capacitance on AM section and with 2 gangs of equal capacitance on FM section , for tuned 520-1750 kHz and oscillation circuit 455 kHz of transistor radio.

2. Electrical Characteristics

2-1. Capacitance

Effective capacitance at each position is shown on Table 1 , defining the rotation angle 180° is expressed 100%.

Table 1 Capacitance & Coefficient

A M					F M		
Rotation	OSC		ANT		OSC / ANT		Rotation
(%)	Coef.	Capa.(pF)	Coef.	Capa.(pF)	Coef.	Capa.(pF)	(%)
*100	100.00	82.00	100.00	160.00	100.00	20.00	*100
90	90.07	73.86	84.40	135.04	86.18	17.24	90
*82.9	81.87	67.13	72.72	116.35	73.37	14.67	80
75	72.06	59.09	60.00	96.00	67.32	13.46	*75
70	65.56	53.76	52.30	83.68	61.48	12.30	70
*59	50.72	41.59	36.66	58.66	50.42	10.08	60
50	39.20	32.14	26.20	41.92	40.12	8.02	*50
*43.5	31.51	25.84	19.98	31.96	30.50	6.10	40
30	17.75	14.56	10.20	16.32	21.52	4.30	30
*28.4	16.34	13.40	9.29	14.87	17.25	3.45	*25
20	9.80	8.04	5.31	8.50	13.11	2.62	20
*15.4	6.61	5.42	3.50	5.60	5.23	1.05	*10
3	0.00	0.00	0.00	0.00	0.00	0.00	3

2-2. Minimum Capacitance

Minimum Capacitance shown on Table 2 is defined at the end stop ,where shaft is rotated full clockwise. But trimmer capacitance is minimum.

Table 2

Section	Minimum Capacitance
AM	C3 : 4.0 ± 1.0pF , C4 : 4.0 ± 1.0pF
FM	C1 : 3.7 ± 1.0pF , C2 : 4.0 ± 1.0pF

2-3. Tolerance of Capacitance

The tolerance of the effective capacitance is shown Table 3

Table3

Condition	Section	Standard
at the angle of * marking of Table 1	OSC	AM ± (1.0% + 1.0 pF) , FM ± (0.5 pF)
	ANT	AM ± (1.0% + 1.0 pF) , FM ± (0.5 pF)

Clause	Item	Condition	Standard
2 - 4	Insulation Resistance	at D.C. 100V	More than 100 MΩ
2 - 5	Voltage Proof	running D.C 100V for 1 minute	Without damage
2 - 6	Q Characteristics	AM	Valued at 10MHz 50pF More than 500
		FM	Valued at 100MHz 10pF More than 200
2 - 7	Contact Resistance	Valued at the tops of shaft and Earth terminals when 1kHz ± 200Hz and 100mA are supplied (Rotation speed 30 times/minute)	Less than 20 mΩ

3. Mechanical Characteristics

Clause	Item	Condition	Standard
3 - 1	Direction of the rotation	Capacitance change when shaft is rotated clockwise	Decreasing
3 - 2	Shaft rotation	rotation range is defined 100% for 180°	97 ⁺² ₋₁ %
3 - 3	Rotation torque	torque application when shaft is rotated full at normal temperature condition	100 - 350 gf-cm
3 - 4	Strength of end stop	a specimen is left in the standard test condition for 10 second after 5 Kgf-cm rotations	not to be found unusually both electrically and mechanically
3 - 5	Ratio of Max. & Min. torque	Maximum : Minimum	Within 3 : 1

4. Trimmer ability

Clause	Item	Condition	Standard
4 - 1	Shaft rotation	Rotation range	360°
4 - 2	Rotation Torque	on the whole rotation range. ratio of Max. & Min. Torque	50 - 350 gf-cm (Max. : Min.) Within 3 : 1
4 - 3	Effective capacitance		more than 5 pF
4 - 4	Q Characteristics	at maximum capacitance and 10 MHz (main capacitance is minimum)	more than 200

5. Materials

5-1. Body Parts

Component	Materials
Base	Degeneration PPO or PPE included glass
Case	Degeneration PP or AS
Rotor Shaft	Brass
Rotor Plate	Aluminum or Brass
Stator Plate	Aluminum - Polyethylene film
Terminal	Iron or Brass - Tin plating

5-2. Trimmer Parts

Component	Materials
Trimmer Base	Degeneration PPO or PPE included glass
Trimmer Shaft	Brass or Copper Alloys
Trimmer Rotor Plate	Brass - Nickel plating
Trimmer Stator Plate	Brass - Polypropylene film

6. Specific Examinations

Clause	Item	Condition	Standard
6 - 1	Vibration	by the vibration with frequency 10-55-10HZ/minute . 2.0mm to three directions of maximum capacitance for 2 hours.	Clattering or loosening shall not be occurred. Satisfying
6 - 2	Load (at maximum capacitance)	Parallel load : 2 Kg weight is loaded to the shaft for 10 second and removing.	Clauses 2-4 , 2-5 , 2-6 , 2-7 and 3-3. Capacitance drift within $\pm 2\%$ or \pm
		Perpendicular load : 1 Kg weight is loaded to the shaft for 10 second	
6 - 3	Impact	by letting a specimen fall down from the height of 50 cm three times to a wooden board , or by giving impact of 80 grams to 6 faces of the specimen on time each.	0.5pF against initial value at maximum capacitance.
6 - 4	Rotation Life	by 10000 rotations with 10 rotations per minute $90\pm 5\%$ rotation range.	
6 - 5	Heat Endurance	a specimen is kept in a chamber with constant temperature $70\pm 2^{\circ}\text{C}$ for 16 hours and left in the standard test condition for one or two hours.	Satisfying clauses 2-4 , 2-6 , 4-2 , 4-3 and 4-4
6 - 6	Cold Endurance	a specimen is kept in a chamber with constant temperature $-20\pm 2^{\circ}\text{C}$ for 16hours and left in the standard test condition for one or two hours.	
6 - 7	Soldering (Terminals)	The end part 2mm of the terminal are given temperature $350\pm 5^{\circ}\text{C}$ for 2 ± 0.5 seconds.	Satisfying clauses 2-4 , 2-5 , 2-6 , 2-7 , 3 and 4.

6-8. Temperature Cycles(double heat treatment, humidity 65~70%)

A specimen at maximum capacitance is kept in the chamber (one is cold , another is hot) with constant temperature and humidity in every stage on table 4 and left in the standard test condition for 1 hour, Clattering or loosening shall not be occurred. Satisfying clauses 2-4 , 2-6 , and 3-3. Max. capacitance variation rate : within 2.0%

Table 4

Stage	1	2	3	4	5	6	7	8
Temperature $\pm 2^{\circ}\text{C}$	-20	70	-20	70	-20	70	-20	70
Time (Hour)	1	2	1	2	1	2	1	1

6-9. Humidity Endurance

A specimen is kept in a chamber with temperature $40\pm 2^{\circ}\text{C}$ and relative humidity 90% to 95% for 96 hours. And after leaving in the standard test condition for one or two hours. The specimen is valued , and the results shall satisfy table 5.

Table 5

		A M side	F M side
Insulation Resistance		more than 50 (D.C. 100V)	
Q	Body	more than 500 (10MHz 50pF)	More than 150 (100MHz 10pF)
Characteristics	Trimmer	more than 150 (10 MHz C max)	
Max. Capacitance Drift		within $\pm 2\%$	

✘The standard test condition

This means the condition of temperature 5 to 35°C and relative humidity 45 to 85% , but that of $20\pm 2^{\circ}\text{C}$ and $65\pm 5\%$ if there is any doubt. ✘All parts clean

AM curve-JWA

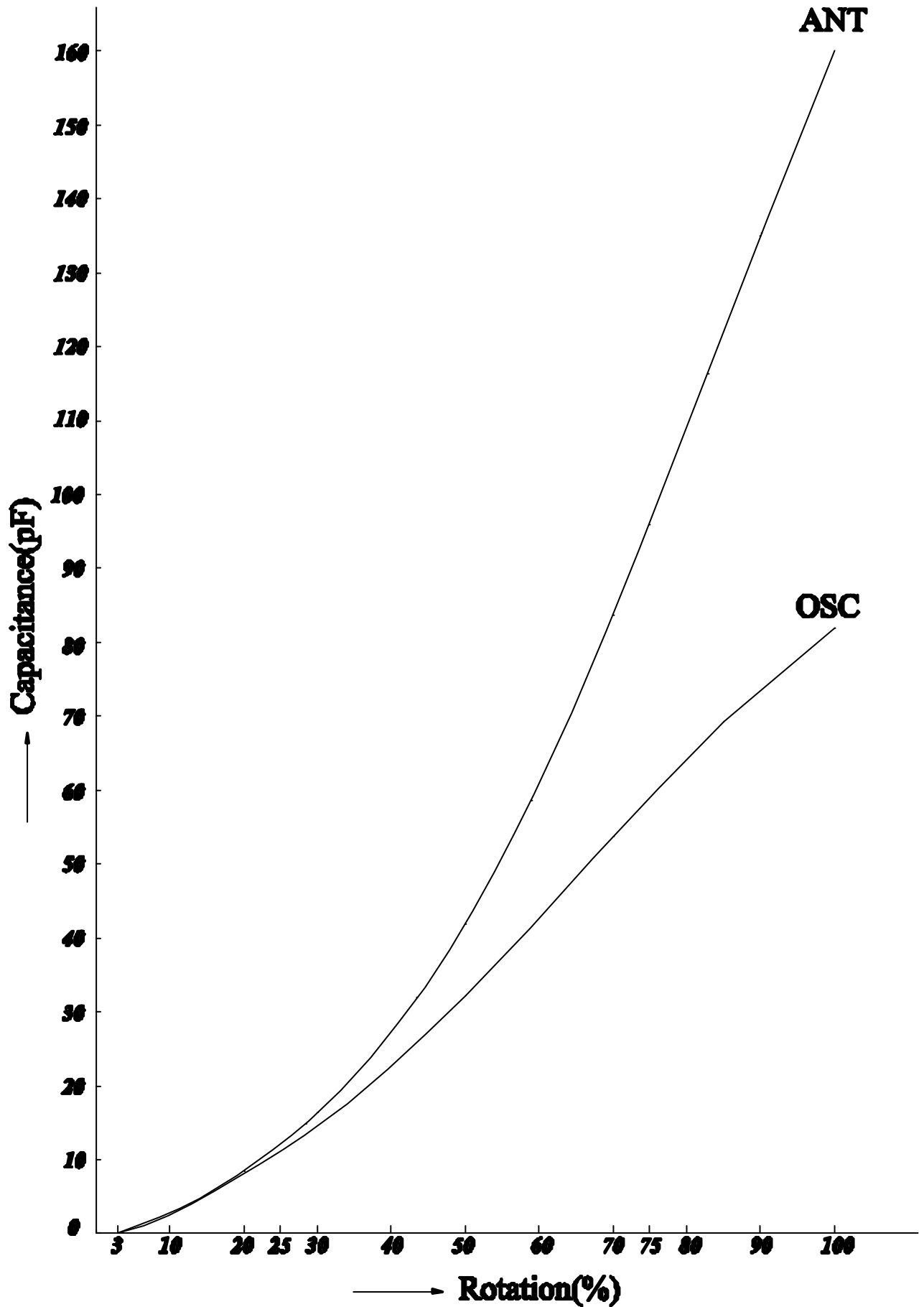

FM curve-FB

