

APPROVAL

DESCRIPTION : TUN-CAP 40-140P 20 × 20A

NCE PARTS NO. : HE443CAB02-A04

PARTS NO. :

RAWING :

RECEIVED

VENDOR:NEWCONT ELE.CO.,LTD.

ADD: 14 Floor,Block C Electronics Science & Technology

Building Shennanzhonglu ,Shenzhen,Guangdong,P.R.China

TEL:86-755-83274500

FAX:86-755-83274577

[Http://www.newcont.com](http://www.newcont.com)

E-mail:pvc@newcont.com

NCE

POLYVARICON

MODEL: HE443CAB02-A04

新大陆电子有限公司
NEWCONT ELE. CO., LTD.

地址：中国、广东、深圳市深南中路 2070 号电子科技大厦
C 座 14 层

ADD: 14 Floor, Block C Electronics Science & Technology
Building Shemanzhonglu, Shenzhen, Guangdong, P.R. China

TEL: 86-755-83274500

FAX: 86-755-83274577

[Http://www.newcont.com](http://www.newcont.com)

E-mail: pvc@newcont.com

Outline drawing

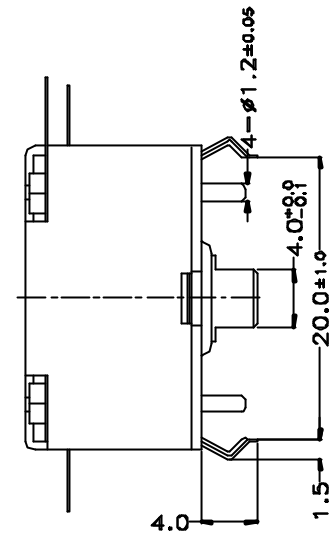
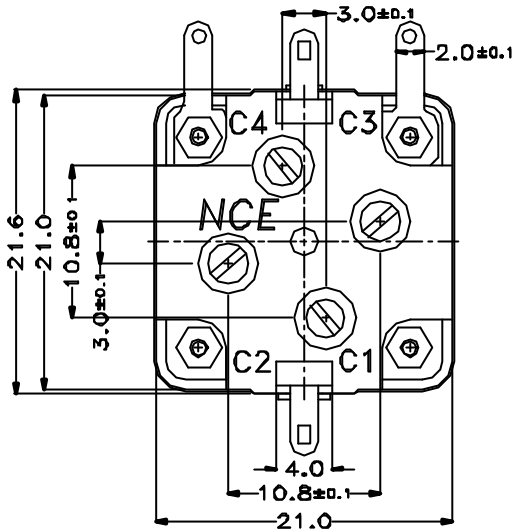

Mounting hole detail

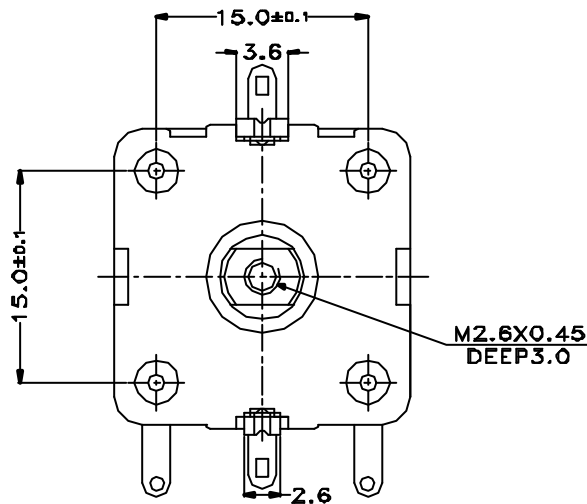
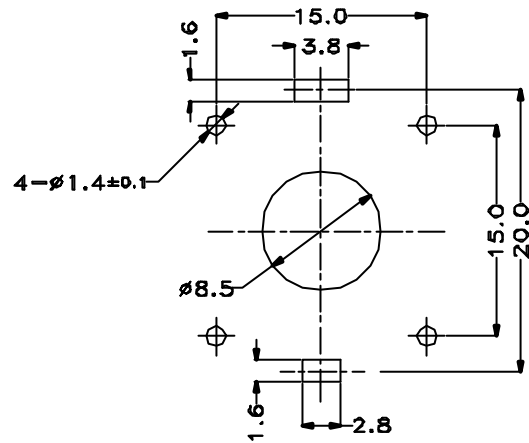
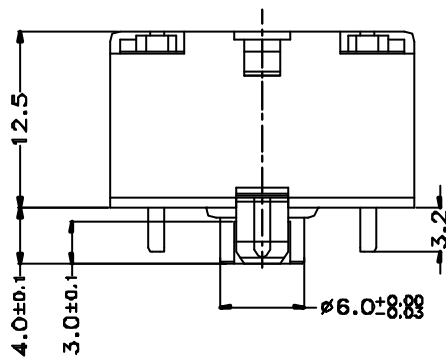

- C1: FM OSC**
- C2: FM ANT**
- C3: AM OSC**
- C4: AM ANT**

REVISIONS	APPEARANCE		MODEL
	UNIT: mm	SCALE: 2/1	HF443CAB02-A04
	DIMENSION TOLERANCE GENERAL ± 0.3		CODE NUMBER
	DESIGNED BY: WISDOM TIAN		190-02-02
	DRAWN BY: WISDOM TIAN		NCE
	CHECKED BY: WISDOM TIAN		
	APPROVED BY: L.K.ZHANG		

3. Mechanical Characteristics

Clause	Item	Condition	Standard
3 - 1	Direction of the rotation	Capacitance change when shaft is rotated clockwise	Decreasing
3 - 2	Shaft Rotation	Rotation range is defined 100% for 180 °	97% (+2 to -1%)
3 - 3	Rotation Torque	Torque application when shaft is rotated full at normal temperature condition	50-400 gf.cm
3 - 4	Strength of end stop	A specimen is left in the standard test condition for 1 minute after 5 kgf.cm rotations	Not to be found insulate both electrically and mechanically
3 - 5	Ratio of Max. and Min. torque	Max.: Min.	Within 3: 1

4. Trimmer ability

Clause	Item	Condition	Standard
4 - 1	Shaft Rotation	Rotation range	360 °
4 - 2	Rotation Torque	On the whole rotation range. Ratio of Max. and Min. torque	50-400 gf.cm Max.: Min. within 3 : 1
4 - 3	Effective Capacitance		More than 5 pF
4 - 4	Q Characteristics	At maximum capacitance and 10 MHz(main capacitance is minimum)	More than 200

5. Materials

5-1. Body Parts

Component	Materials
Base	Degeneration PPO or PPE included glass
Case	Degeneration PP or AS
Rotor Shaft	Brass
Rotor Plate	Aluminum or Brass
Stator Plate	Aluminum - Polyethylene film
Terminal	Iron or Brass - Tin plating

5-2. Trimmer Parts

Component	Materials
Trimmer Base	Degeneration PPO or PPE included glass
Trimmer Shaft	Brass or Copper Alloys
Trimmer Rotor Plate	Brass - Nickel plating
Trimmer Stator Plate	Brass - Polypropylene film

6. Specific Examinations

Clause	Item	Condition	Standard
6 - 1	Vibration	By the vibration with frequency 10-55-10HZ/minute. 2.0mm to three directions of maximum capacitance for 2 hours.	Clattering or loosening shall not be occurred.
6 - 2	Load (at maximum capacitance)	Parallel load: 2kg weight is loaded to the shaft for 10 second and removing.	Satisfying clauses 2-4, 2-5, 2-6, 2-7 and 3-3.
		Perpendicular load: 1kg weight is loaded to the shaft for 10 seconds.	
6 - 3	Impact	By letting a specimen fall down from the height of 50 cm three times to a wooden board, or by giving impact of 80 grams to 6 faces of the specimen on time each.	Capacitance drift within $\pm 2\%$ or $\pm 0.5\text{pF}$ against initial value at maximum effective capacitance.
6 - 4	Rotation Life	By 10000 rotations with 10-15 rotations per minute $80\pm 5\%$ rotation range.	
6 - 5	Heat Endurance	A specimen is kept in a chamber with constant temperature 70 ± 2 for 16 hours and left in the standard test condition for one or two hours.	Satisfying clauses 2-4 , 2-6 , 4-2 , 4-3 and 4-4
6 - 6	Cold Endurance	A specimen is kept in a chamber with constant temperature -20 ± 2 for 16 hours and left in the standard test condition for one or two hours.	
6 - 7	Soldering (Terminals)	The end part 2mm of the terminal are given temperature 270 ± 5 for 2 ± 0.5 seconds.	Satisfying clauses 2-4, 2-5, 2-6, 2-7, 3 and 4.

6-8. Temperature Cycles

A specimen at maximum capacitance is kept in the chamber (one is cold, another is hot) with constant temperature and humidity in every stage on table 4 and left in the standard test condition for 1 hour, clattering or loosening shall not be occurred. Satisfying clauses 2-4, 2-6, and 3-3. Maximum capacitance variation rate : within 2.0%

Table 4

Stage	1	2	3	4	5	6	7	8
Temperature ± 2	-20	70	-20	70	-20	70	-20	70
Time (Hour)	1	1	1	1	1	1	1	1

6-9. Humidity Endurance

A specimen is kept in a chamber with temperature 40 ± 2 and relative humidity 90% to 95% for 96 hours. And after leaving in the standard test condition for one or two hours. The specimen is valued, and the results shall satisfy table 5.

Table 5

		AM side	FM side
Insulation Resistance		More than 50 M (D.C. 100V)	
Q	Body	More than 500 (10MHz 50pF)	More than 150 (100MHz 10pF)
Characteristics	Trimmer	More than 150 (10 MHz Cmax)	
Maximum Capacitance Drift		Within $\pm 2\%$	

The standard test condition

This means the condition of temperature 5 to 35 and relative humidity 45 to 85% , but that of 20 ± 2 and $65\pm 5\%$ if there is any doubt.

AM curve-HCA

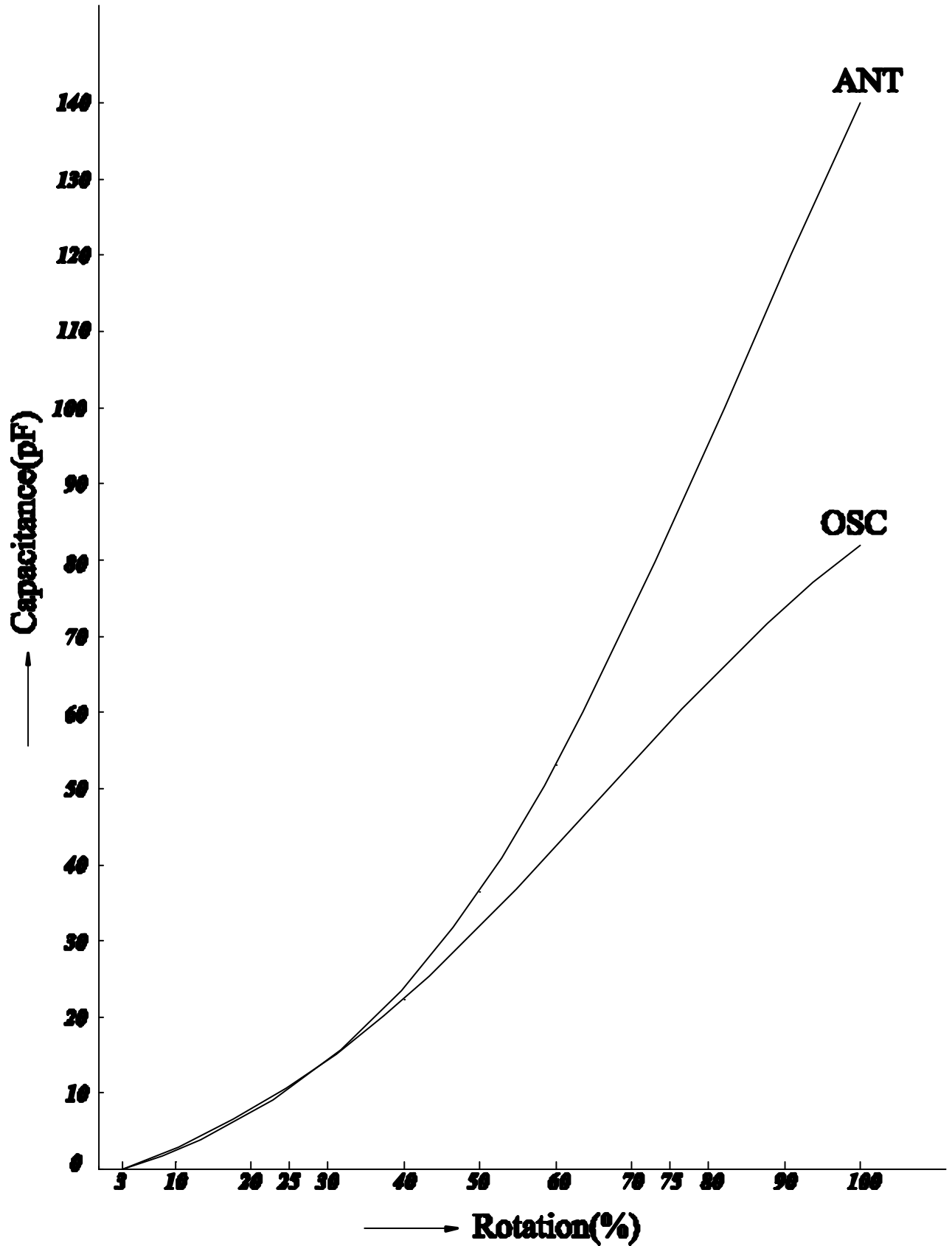

FM curve-FB

