

APPROVAL

DESCRIPTION : TUN-CAP 20P-160P 16 × 16A

NCE PARTS NO. : JF444WAB22-A1.0

PARTS NO. :

DRAWING :

RECEIVED

VENDOR:NEWCONT ELE.CO.,LTD.

ADD: 40Floor,Block C Electronics Science & Technology

Building Shennanzhonglu ,Shenzhen,Guangdong,P.R.China

TEL:86-755-83274500

FAX:86-755-83274577

[Http://www.nce-newcont.com](http://www.nce-newcont.com)

E-mail:pvc@newcont.com

NCE

POLYVARICON

MODEL: JF444WAB22-A1.0

新大陆电子有限公司
NEWCONT ELE. CO., LTD.

地址：中国、广东、深圳市深南中路 2070 号电子科技大厦
C 座 40 层

ADD: 40 Floor, Block C Electronics Science & Technology
Building Shennanzhonglu, Shenzhen, Guangdong, P.R. China

TEL: 86-755-83274500

FAX: 86-755-83274577

[Http://www.nce-newcont.com](http://www.nce-newcont.com)

E-mail: pvc@newcont.com

Outline drawing

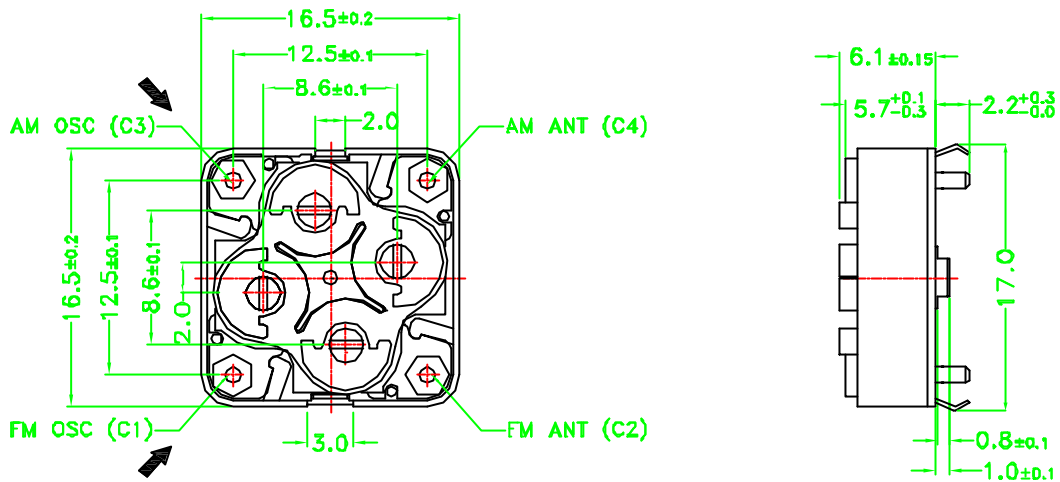

Mounting hole detail

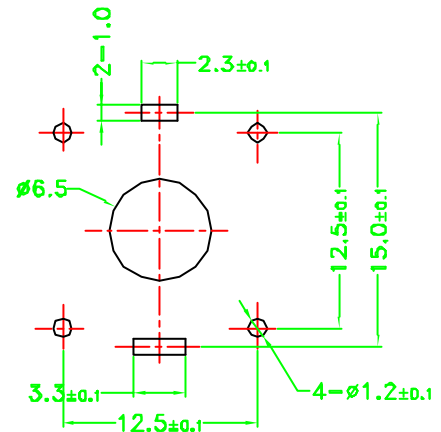
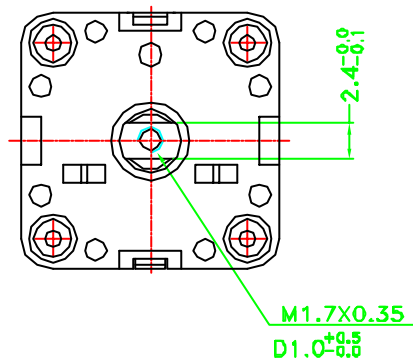
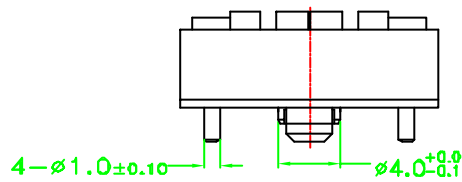

- ➔ C1: FM OSC
- ➔ C2: FM ANT
- ➔ C3: AM OSC
- ➔ C4: AM ANT

| REVISIONS | APPEARANCE | MODEL |
|-----------|--------------------------------------|-----------------|
| | UNIT: mm SCALE: 2/1 | JF444WAB22-A1.0 |
| | DIMENSION TOLERANCE GENERAL ± 0.3 | CODE NUMBER |
| | DESIGNED BY: WISDOM TIAN | 192-22-01 |
| | DRAWN BY: WISDOM TIAN | NCE |
| | CHECKED BY: WISDOM TIAN | |
| | APPROVED BY: L.K.ZHANG | |

1. Application

This specification is applicable for 4 gangs capacitor , model **JF444WAB22-A1.0** with 2 gangs of different capacitance on AM section and with 2 gangs of equal capacitance on FM section, for tuned 520-1750 kHz and oscillation circuit 450 kHz of transistor radio.

2. Electrical Characteristics

2-1. Capacitance

Effective capacitance at each position is shown on Table 1 , defining the rotation angle 180 ° is expressed 100%.

Table 1 Capacitance & Coefficient

| A M | | | | | F M | | |
|----------|--------|-----------|--------|-----------|-----------|-----------|----------|
| Rotation | OSC | | ANT | | OSC / ANT | | Rotation |
| (%) | Coef. | Capa.(pF) | Coef. | Capa.(pF) | Coef. | Capa.(pF) | (%) |
| *100 | 100.00 | 82.00 | 100.00 | 160.00 | 100.00 | 20.00 | *100 |
| 90 | 90.07 | 73.86 | 84.40 | 135.04 | 86.18 | 17.24 | 90 |
| *82.9 | 81.87 | 67.13 | 72.72 | 116.35 | 73.37 | 14.67 | 80 |
| 75 | 72.06 | 59.09 | 60.00 | 96.00 | 67.32 | 13.46 | *75 |
| 70 | 65.56 | 53.76 | 52.30 | 83.68 | 61.48 | 12.30 | 70 |
| *59 | 50.72 | 41.59 | 36.66 | 58.66 | 50.42 | 10.08 | 60 |
| 50 | 39.20 | 32.14 | 26.20 | 41.92 | 40.12 | 8.02 | *50 |
| *43.5 | 31.51 | 25.84 | 19.98 | 31.97 | 30.50 | 6.10 | 40 |
| 30 | 17.75 | 14.56 | 10.20 | 16.32 | 21.52 | 4.30 | 30 |
| *28.4 | 16.34 | 13.40 | 9.29 | 14.86 | 17.25 | 3.45 | *25 |
| 20 | 9.80 | 8.04 | 5.31 | 8.50 | 13.11 | 2.62 | 20 |
| *15.4 | 6.61 | 5.42 | 3.50 | 5.60 | 5.23 | 1.05 | *10 |
| 3 | 0.00 | 0.00 | 0.00 | 0.00 | 0.00 | 0.00 | 3 |

2-2. Minimum Capacitance

Minimum Capacitance shown on Table 2 is defined at the end stop, where shaft is rotated full clockwise. But trimmer capacitance is minimum.

Table 2

| Section | Minimum Capacitance |
|---------|-------------------------------------|
| AM | C3 : 4.7 ± 1.0pF , C4 : 4.7 ± 1.0pF |
| FM | C1 : 4.9 ± 1.0pF , C2 : 4.8 ± 1.0pF |

2-3. Tolerance of Capacitance

The tolerance of the effective capacitance is shown Table 3

Table 3

| Condition | Section | Standard |
|--------------------------------------|---------|--|
| At the angle of * marking of Table 1 | OSC | AM ± (2.0% + 2.0 pF) , FM ± (1.5% + 1.5 p F) |
| | ANT | AM ± (2.0% + 2.0 pF) , FM ± (1.5% + 1.5 p F) |

| Clause | Item | Condition | Standard |
|--------|-----------------------|--|---------------------------|
| 2 - 4 | Insulation Resistance | At D.C. 100V | More than 100 M |
| 2 - 5 | Voltage Proof | Running D.C. 100V for 1 minute | Not to be found unusually |
| 2 - 6 | Q Characteristics | AM | Valued at 10MHz 50pF |
| | | FM | Valued at 100MHz 10pF |
| 2 - 7 | Contact Resistance | Valued at the tops of shaft and earth terminals when 1kHz ± 200Hz and 100mA are supplied(Rotation speed 30 times/minute) | Less than 20 m |

3. Mechanical Characteristics

| Clause | Item | Condition | Standard |
|--------|-------------------------------|---|---|
| 3 - 1 | Direction of the rotation | Capacitance change when shaft is rotated clockwise | Decreasing |
| 3 - 2 | Shaft Rotation | Rotation range is defined 100% for 180 ° | 97% (+2 to -1%) |
| 3 - 3 | Rotation Torque | Torque application when shaft is rotated full at normal temperature condition | 50-250 gf.cm |
| 3 - 4 | Strength of end stop | A specimen is left in the standard test condition for 1 minute after 3 kgf.cm rotations | Not to be found insulate both electrically and mechanically |
| 3 - 5 | Ratio of Max. and Min. torque | Max.: Min. | Within 3: 1 |

4. Trimmer ability

| Clause | Item | Condition | Standard |
|--------|-----------------------|--|---|
| 4 - 1 | Shaft Rotation | Rotation range | 360 ° |
| 4 - 2 | Rotation Torque | On the whole rotation range. Ratio of Max. and Min. torque | 50-300 gf-cm Max.: Min. within 3 : 1 |
| 4 - 3 | Effective Capacitance | | More than 5 pF |
| 4 - 4 | Q Characteristics | At maximum capacitance and 10 MHz(main capacitance is minimum) | More than 200 |

5. Materials

5-1. Body Parts

| Component | Materials |
|--------------|--|
| Base | Degeneration PPO or PPE included glass |
| Case | Degeneration PP or AS |
| Rotor Shaft | Brass |
| Rotor Plate | Aluminum or Brass |
| Stator Plate | Aluminum - Polyethylene film |
| Terminal | Iron or Brass - Tin plating |

5-2. Trimmer Parts

| Component | Materials |
|----------------------|--|
| Trimmer Base | Degeneration PPO or PPE included glass |
| Trimmer Shaft | Brass or Copper Alloys |
| Trimmer Rotor Plate | Brass - Nickel plating |
| Trimmer Stator Plate | Brass - Polyethylene film |

6. Specific Examinations

| Clause | Item | Condition | Standard |
|--------|-------------------------------|--|--|
| 6 - 1 | Vibration | By the vibration with frequency 10-55-10HZ/minute. 2.0mm to three directions of maximum capacitance for 2 hours. | Clattering or loosening shall not be occurred. |
| 6 - 2 | Load (at maximum capacitance) | Parallel load: 2kg weight is loaded to the shaft for 10 second and removing. | Satisfying clauses 2-4, 2-5, 2-6, 2-7 and 3-3. |
| | | Perpendicular load: 1kg weight is loaded to the shaft for 10 seconds. | |
| 6 - 3 | Impact | By letting a specimen fall down from the height of 50 cm three times to a wooden board, or by giving impact of 80 grams to 6 faces of the specimen on time each. | Capacitance drift within $\pm 2\%$ or $\pm 0.5\text{pF}$ against initial value at maximum effective capacitance. |
| 6 - 4 | Rotation Life | By 10000 rotations with 10-15 rotations per minute $80\pm 5\%$ rotation range. | |
| 6 - 5 | Heat Endurance | A specimen is kept in a chamber with constant temperature 70 ± 2 for 16 hours and left in the standard test condition for one or two hours. | Satisfying clauses 2-4 , 2-6 , 4-2 , 4-3 and 4-4 |
| 6 - 6 | Cold Endurance | A specimen is kept in a chamber with constant temperature -20 ± 2 for 16 hours and left in the standard test condition for one or two hours. | |
| 6 - 7 | Soldering (Terminals) | The end part 2mm of the terminal are given temperature 270 ± 5 for 2 ± 0.5 seconds. | Satisfying clauses 2-4, 2-5, 2-6, 2-7, 3 and 4. |

6-8. Temperature Cycles

A specimen at maximum capacitance is kept in the chamber (one is cold, another is hot) with constant temperature and humidity in every stage on table 4 and left in the standard test condition for 1 hour, clattering or loosening shall not be occurred. Satisfying clauses 2-4, 2-6, and 3-3. Maximum capacitance variation rate : within 2.0%

Table 4

| Stage | 1 | 2 | 3 | 4 | 5 | 6 | 7 | 8 |
|---------------------|-----|----|-----|----|-----|----|-----|----|
| Temperature ± 2 | -20 | 70 | -20 | 70 | -20 | 70 | -20 | 70 |
| Time (Hour) | 1 | 1 | 1 | 1 | 1 | 1 | 1 | 1 |

6-9. Humidity Endurance

A specimen is kept in a chamber with temperature 40 ± 2 and relative humidity 90% to 95% for 96 hours. And after leaving in the standard test condition for one or two hours. The specimen is valued, and the results shall satisfy table 5.

Table 5

| | | AM side | FM side |
|---------------------------|---------|-------------------------------|-----------------------------|
| Insulation Resistance | | More than 50 M (D.C. 100V) | |
| Q | Body | More than 500 (10MHz 50pF) | More than 150 (100MHz 10pF) |
| Characteristics | Trimmer | More than 150 (10 MHz Cmax) | |
| Maximum Capacitance Drift | | Within $\pm 2\%$ | |

The standard test condition

This means the condition of temperature 5 to 35 and relative humidity 45 to 85% , but that of 20 ± 2 and $65\pm 5\%$ if there is any doubt.

AM curve-JWA

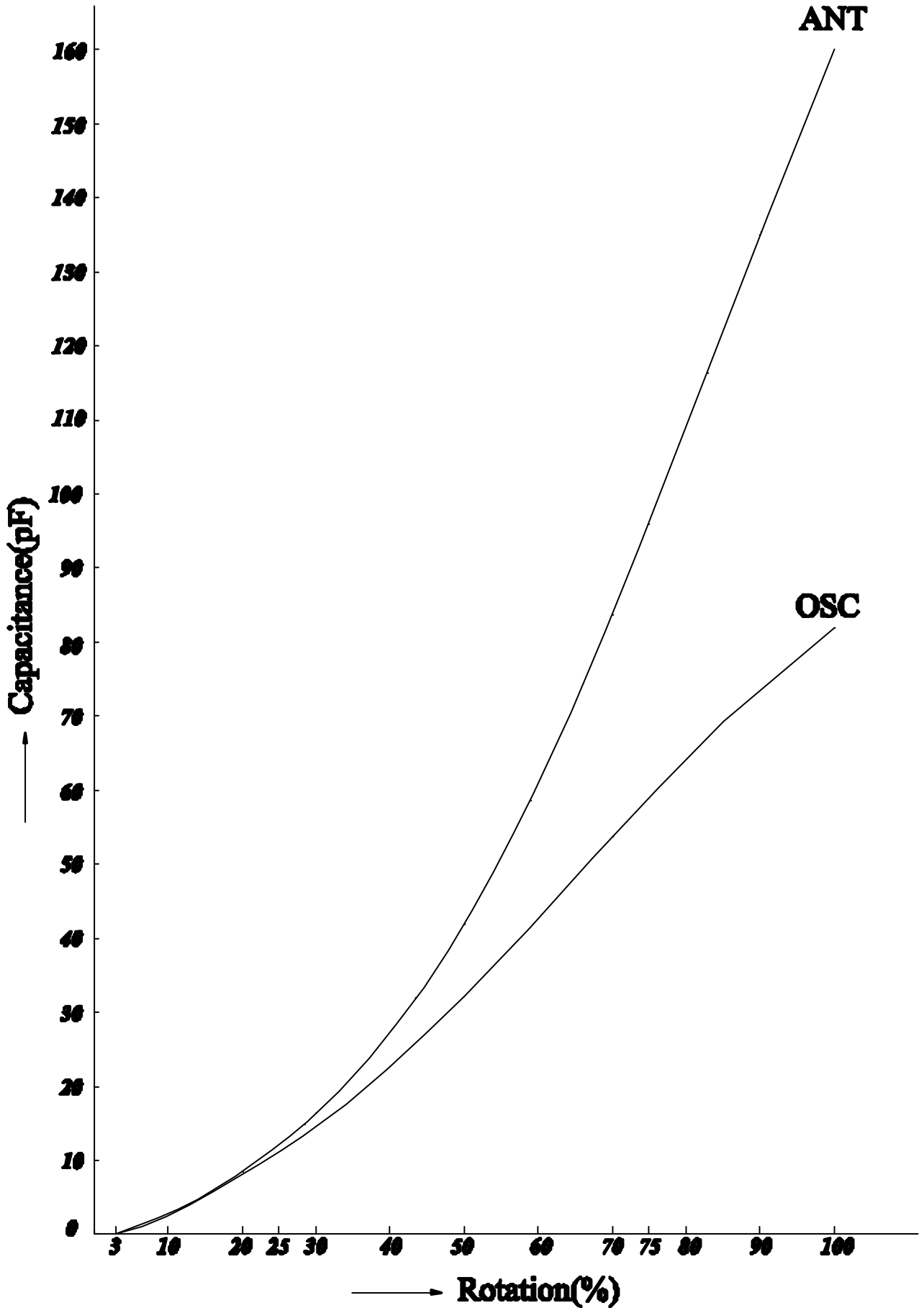

FM curve-FB

