

APPROVAL

DESCRIPTION : TUN-CAP 20-140P 16 × 16A

NCE PARTS NO. : HF444CAB82-A1.5D

PARTS NO. :

DRAWING :

RECEIVED

VENDOR:UNITY SYSTEMS.CO.,LTD.

**ADD: 17 Floor,Block WEST Qiushi building,zhuzilinlu,
Shennandadao ,Shenzhen,Guangdong,P.R.China**

TEL:86-755-88316650

FAX:86-755-88316651

[Http://www.nce-newcont.com](http://www.nce-newcont.com)

E-mail:pvc@newcont.com

NCE

POLYVARICON

MODEL: HF444CAB82-A1.5D

UNITY SYSTEMS. CO., LTD.

**ADD: 17Floor, Block WEST Qiushi building, zhuzilinlu,
Shennandadao, Shenzhen, Guangdong, P.R. China**

TEL: 86-755-88316650

FAX: 86-755-88316651

[Http://www.nce-newcont.com](http://www.nce-newcont.com)

E-mail: pvc@newcont.com

Outline drawing

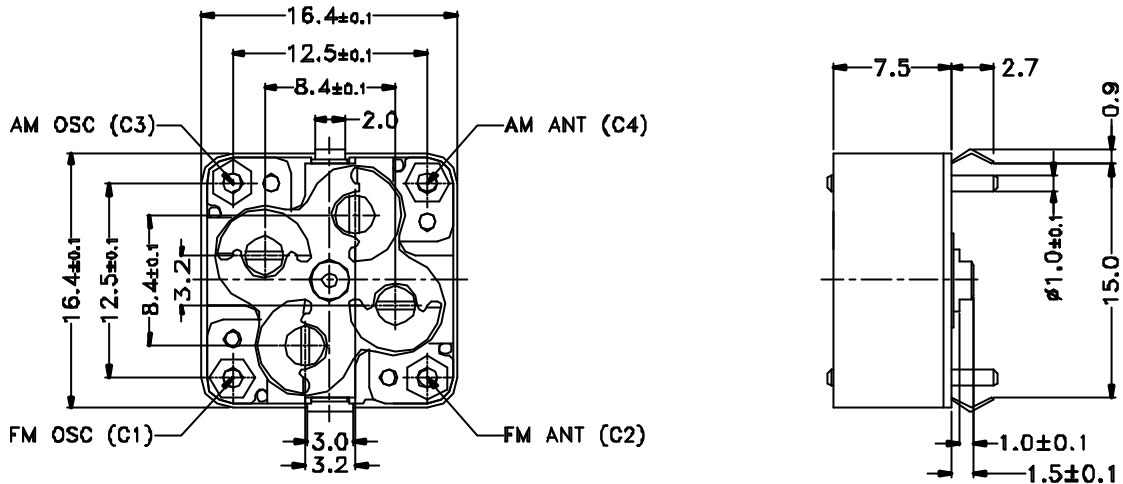

Mounting hole detail

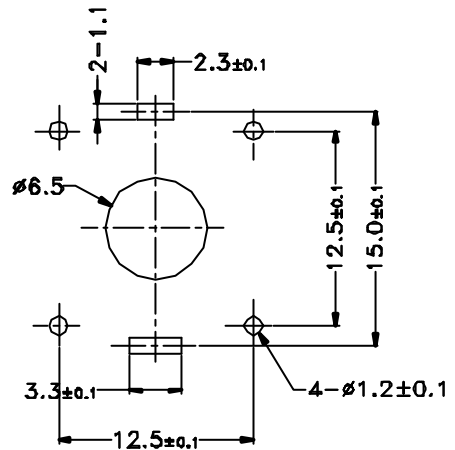
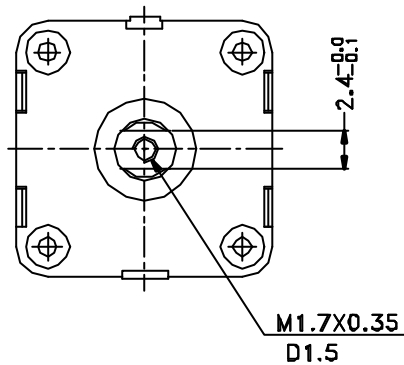
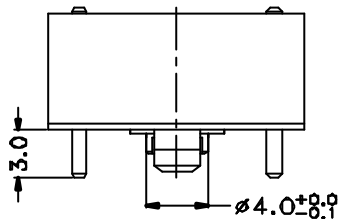

REVISIONS	APPEARANCE		MODEL
	UNIT: mm	SCALE: 2/1	HF444CAB82-A1.5D
	DIMENSION TOLERANCE GENERAL ± 0.3		CODE NUMBER
	DESIGNED BY: WISDOM TIAN		188-82-01
	DRAWN BY: WISDOM TIAN		NCE
	CHECKED BY: LASER YANG		
	APPROVED BY: L.K.ZHANG		

1. Application

This specification is applicable for 4 gangs capacitor , model **HF444CAB82-A1.5D** with 2 gangs of different capacitance on AM section and with 2 gangs of equal capacitance on FM section, for tuned 520-1650kHz and oscillation circuit 455kHz of transistor radio.

2. Electrical Characteristics

2-1. Capacitance

Effective capacitance at each position is shown on Table 1 , defining the rotation angle 180 ° is expressed 100%.

Table 1 Capacitance & Coefficient

A M					F M		
Rotation	OSC		ANT		OSC / ANT		Rotation
(%)	Coef.	Capa.(pF)	Coef.	Capa.(pF)	Coef.	Capa.(pF)	(%)
*100	100.00	82.00	100.00	140.00	100.00	20.00	*100
90	90.00	73.80	84.40	118.16	86.18	17.24	90
*80	78.00	63.96	67.90	95.06	73.37	14.67	80
75	71.80	58.88	60.00	84.00	67.32	13.46	*75
70	65.20	53.46	52.30	73.22	61.48	12.30	70
*60	51.70	42.39	38.00	53.20	50.42	10.08	60
50	38.80	31.82	26.20	36.68	40.12	8.02	*50
*40	27.20	22.30	17.00	23.80	30.50	6.10	40
30	17.40	14.27	10.20	14.28	21.52	4.30	30
*25	13.30	10.91	7.57	10.60	17.25	3.45	*25
20	9.60	7.87	5.31	7.43	13.11	2.62	20
*10	3.30	2.71	1.74	2.44	5.23	1.05	*10
3	0.00	0.00	0.00	0.00	0.00	0.00	3

2-2. Minimum Capacitance

Minimum Capacitance shown on Table 2 is defined at the end stop, where shaft is rotated full clockwise. But trimmer capacitance is minimum.

Table 2

Section	Minimum Capacitance
AM	C3 : $4.2 \pm 1.0\text{pF}$, C4 : $4.0 \pm 1.0\text{pF}$
FM	C1 : $3.8 \pm 1.0\text{pF}$, C2 : $3.8 \pm 1.0\text{pF}$

2-3. Tolerance of Capacitance

The tolerance of the effective capacitance is shown Table 3

Table 3

Condition	Section	Standard
At the angle of * marking of Table 1	OSC	AM \pm (2.0% + 1.0 pF) , FM \pm (1.0% + 1.0 p F)
	ANT	AM \pm (2.0% + 1.0 pF) , FM \pm (1.0% + 1.0 p F)

Clause	Item	Condition	Standard
2 - 4	Insulation Resistance	At D.C. 100V	More than 100 M
2 - 5	Voltage Proof	Running D.C. 100V for 1 minute	Not to be found unusually
2 - 6	Q Characteristics	AM	Valued at 10MHz 50pF
		FM	Valued at 100MHz 10pF
2 - 7	Contact Resistance	Valued at the tops of shaft and earth terminals when 1kHz \pm 200Hz and 100mA are supplied(Rotation speed 30 times/minute)	Less than 20 m

3. Mechanical Characteristics

Clause	Item	Condition	Standard
3 - 1	Direction of the rotation	Capacitance change when shaft is rotated clockwise	Decreasing
3 - 2	Shaft Rotation	Rotation range is defined 100% for 180 °	97% (+2 to -1%)
3 - 3	Rotation Torque	Torque application when shaft is rotated full at normal temperature condition	50-300 gf.cm
3 - 4	Strength of end stop	A specimen is left in the standard test condition for 1 minute after 3 kgf.cm rotations	Not to be found insulate both electrically and mechanically
3 - 5	Ratio of Max. and Min. torque	Max.: Min.	Within 3: 1

4. Trimmer ability

Clause	Item	Condition	Standard
4 - 1	Shaft Rotation	Rotation range	360 °
4 - 2	Rotation Torque	On the whole rotation range. Ratio of Max. and Min. torque	50-300 gf.cm Max.: Min. within 3 : 1
4 - 3	Effective Capacitance		More than 5 pF
4 - 4	Q Characteristics	At maximum capacitance and 10 MHz(main capacitance is minimum)	More than 200

5. Materials

5-1. Body Parts

Component	Materials
Base	Degeneration PPO or PPE included glass
Case	Degeneration PP or AS
Rotor Shaft	Brass
Rotor Plate	Aluminum or Brass
Stator Plate	Aluminum - Polyethylene film
Terminal	Iron or Brass - Tin plating

5-2. Trimmer Parts

Component	Materials
Trimmer Base	Degeneration PPO or PPE included glass
Trimmer Shaft	Brass or Copper Alloys
Trimmer Rotor Plate	Brass - Nickel plating
Trimmer Stator Plate	Brass - Polypropylene film

6. Specific Examinations

Clause	Item	Condition	Standard
6 - 1	Vibration	By the vibration with frequency 10-55-10HZ/minute. 2.0mm to three directions of maximum capacitance for 2 hours.	Clattering or loosening shall not be occurred.
6 - 2	Load (at maximum capacitance)	Parallel load: 1kg weight is loaded to the shaft for 10 second and removing.	Satisfying clauses 2-4, 2-5, 2-6, 2-7 and 3-3.
		Perpendicular load: 1kg weight is loaded to the shaft for 10 seconds.	
6 - 3	Impact	By letting a specimen fall down from the height of 50 cm three times to a wooden board, or by giving impact of 80 grams to 6 faces of the specimen on time each.	Capacitance drift within $\pm 2\%$ or $\pm 0.5\text{pF}$ against initial value at maximum effective capacitance.
6 - 4	Rotation Life	By 10000 rotations with 10-15 rotations per minute $80\pm 5\%$ rotation range.	
6 - 5	Heat Endurance	A specimen is kept in a chamber with constant temperature 70 ± 2 for 16 hours and left in the standard test condition for one or two hours.	
6 - 6	Cold Endurance	A specimen is kept in a chamber with constant temperature -20 ± 2 for 16 hours and left in the standard test condition for one or two hours.	
6 - 7	Soldering (Terminals)	The end part 2mm of the terminal are given temperature 270 ± 5 for 2 ± 0.5 seconds.	Satisfying clauses 2-4, 2-5, 2-6, 2-7, 3 and 4.

6-8. Temperature Cycles

A specimen at maximum capacitance is kept in the chamber (one is cold, another is hot) with constant temperature and humidity in every stage on table 4 and left in the standard test condition for 1 hour, clattering or loosening shall not be occurred. Satisfying clauses 2-4, 2-6, and 3-3. Maximum capacitance variation rate : within 2.0%

Table 4

Stage	1	2	3	4	5	6	7	8
Temperature ± 2	-20	70	-20	70	-20	70	-20	70
Time (Hour)	1	1	1	1	1	1	1	1

6-9. Humidity Endurance

A specimen is kept in a chamber with temperature 40 ± 2 and relative humidity 90% to 95% for 96 hours. And after leaving in the standard test condition for one or two hours. The specimen is valued, and the results shall satisfy table 5.

Table 5

		AM side	FM side
Insulation Resistance		More than 50 M (D.C. 100V)	
Q	Body	More than 500 (10MHz 50pF)	More than 150 (100MHz 10pF)
Characteristics	Trimmer	More than 150 (10 MHz Cmax)	
Maximum Capacitance Drift		Within $\pm 2\%$	

The standard test condition

This means the condition of temperature 5 to 35 and relative humidity 45 to 85% , but that of 20 ± 2 and $65\pm 5\%$ if there is any doubt.

AM curve-HCA

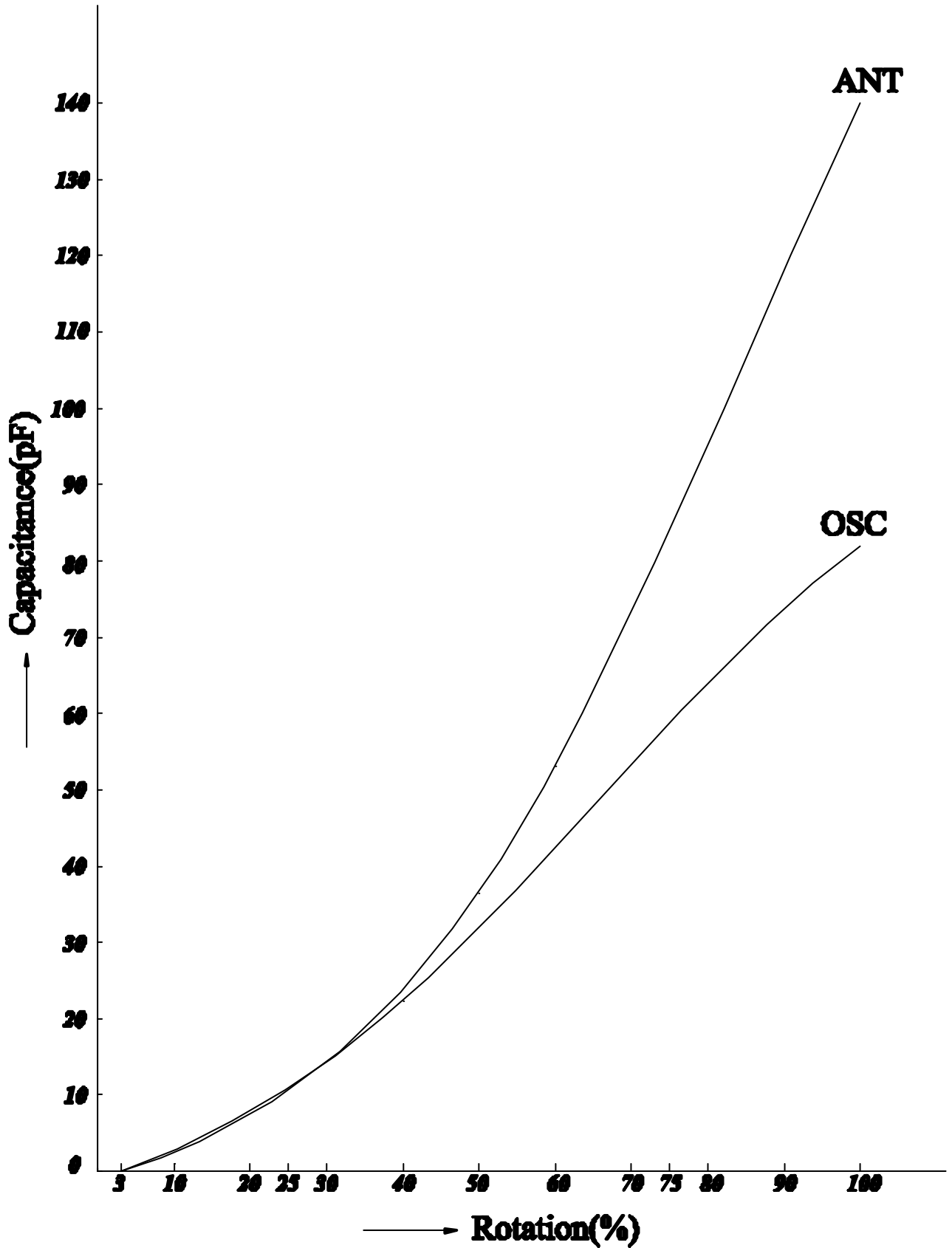

FM curve-FB

