

# APPROVAL

DESCRIPTION :

NCE PARTS NO. : TC03

PARTS NO. :

DRAWING :

**RECEIVED**

**VENDOR:UNITY SYSTEM.CO.,LTD.**

**ADD: 19Floor, Block C QIUSHI building,zhuzhilinlu,  
Shennandadao, Shenzhen,Guangdong,P.R.China**

**TEL:86-755-88316650**

**FAX:86-755-88316651**

**[Http://www.newcont.com](http://www.newcont.com)**

**E-mail:pvc@newcont.com**

# **NCE**

**TRIMMER CAPACITORS**

**MODEL: TC03**

**UNITY SYSTEM. CO., LTD.**

---

**ADD: 19Floor, Block C QIUSHIbuilding, zhuzhilinlu,  
Shennandadao, Shenzhen, Guangdong, P.R. China**

**TEL: 86-755-88316650**

**FAX: 86-755-88316651**

**[Http://www.newcont.com](http://www.newcont.com)**

**E-mail: pvc@newcont.com**

### Outline drawing

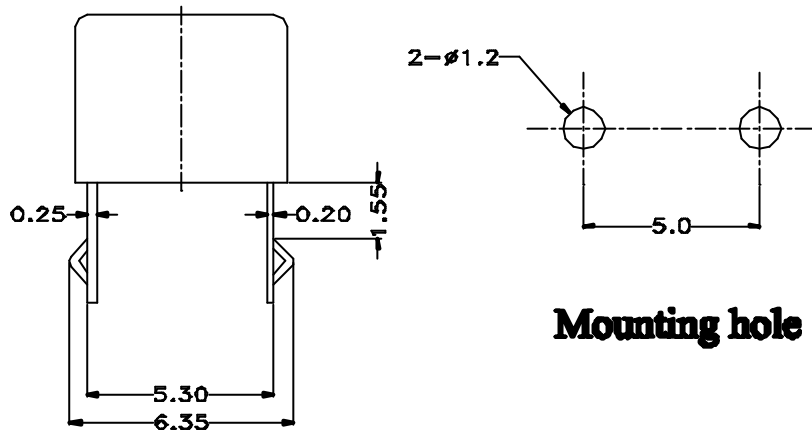
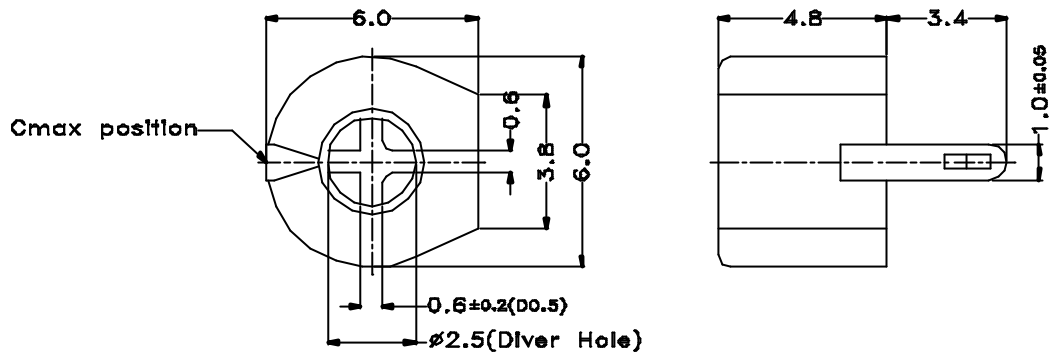

**Mounting hole**

REVISIONS	APPEARANCE		PART NO	
	UNIT: mm	SCALE: 5/1	TC03	
	DIMENSION TOLERANCE GENERAL ± 0.5		TERMINAL	ROTOR
	DESIGNED BY: YANQINGKUN		H	169
	DRAWN BY: YANQINGKUN		<b>NCE</b>	
	CHECKED BY: YANQINGKUN			
	APPROVED BY: XLBAO			

### Outline drawing

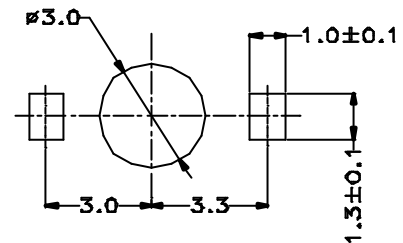
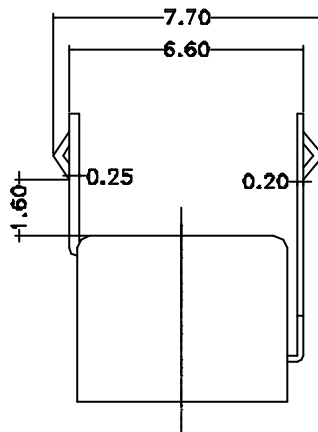
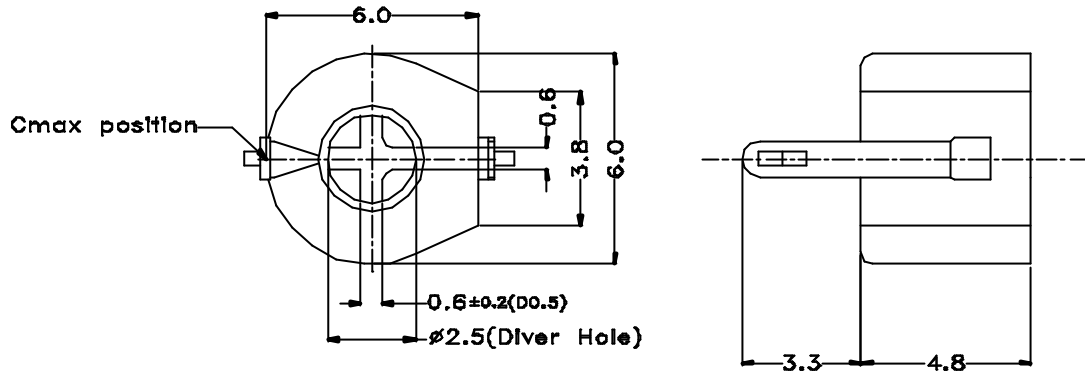

### Mounting hole

REVISIONS	APPEARANCE		PART NO	
	UNIT: mm	SCALE: 5/1	TC03	
	DIMENSION TOLERANCE GENERAL ± 0.5		TERMINAL	ROTOR
	DESIGNED BY: Q.K.YAN		N	169
	DRAWN BY: Q.K.YAN		<b>NCE</b>	
	CHECKED BY: Q.K.YAN			
	APPROVED BY: XLBAO			

**1. Scope**

This specification applies to the ceramic type trimmer capacitor using ceramic as a dielectric.

**2. Main characteristics**

Table 1

Part No.	Capacitance(pF)		Temperature coefficient(ppm/ )	Q factor (1MHz,Cmax)	Marking color
	Min	Max			
TC03Z050H169B00	2.0 or less	5.0+50% 0	NP0 ± 300	500	Blue
TC03Z100H169B00	3.0 or less	10.0+100% 0	NP0 ± 300	500	White
TC03SL200H169B00	5.5 or less	20.0+100% 0	N1200 ± 500	500	Red
TC03SL300H169B00	6.5 or less	30.0+100% 0	N1200 ± 500	500	Green
TC03DL400H169B00	7.0 or less	40.0+100% 0	N2200 ± 800	300	Yellow
TC03DL500H169B00	12.0 or less	50.0+100% 0	N2200 ± 800	300	Orange
TC03DL600H169B00	14.0 or less	60.0+100% 0	N2200 ± 800	300	Brown
TC03D900H169B00	25.0 or less	90.0+100% 0	N3300 ± 1200	300	Brown+black dot
TC03D121H169B00	35.0 or less	120.0+100% 0	N3300 ± 1200	300	Black

**Part number:**

(Global Part Number)

TC - 03 - Z - 050 - H - 169 - B00

Ceramic trimmer capacitors

6mm Size

Temperature characteristics

Cmax

Terminal type(H—— Top Adjustment, N—— Rear Adjustment)

Rotor type(169----- “ + ” type ; 269----- “ T ” type)

Packaging

### 3. Characteristics

#### Standard atmospherics conditions:

Unless otherwise specified, the standard range of atmospherics conditions for making measurements and tests are as follows:

Ambient temperature	:	5 to 35	;
Relative humidity	:	45% to 85%	;
Air pressure	:	86kPa to 106kPa.	

If there is any doubt about the results. measurement shall be made within the following limits:

Ambient temperature	:	20 ± 2	;
Relative humidity	:	60% to 70%	;
Air pressure	:	86kPa to 106kPa.	

#### Operating temperature range:

The operating temperature range is the range of ambient temperature of which the trimmer capacitor can be operated continuously within rated voltage.

-25 to +85

#### Storage temperature range:

The Storage temperature range is the range of ambient temperature at which the trimmer capacitor can be Stored without damage, conditions are as specified elsewhere in these specification.

-25 to +85

#### 3-1 Mechanical characteristics:

	Items	Conditions	Specification
1	Rotational torque	When the spindle is rotated at a rate of 10 rpm	2.0~20.0Nm (20~200gf.cm)
2	Difference between the maximum and minimum value of rotational torque	Difference between the maximum value and the minimum value when the shaft is rotated at a rate of 10 rpm	3 : 1 or less
3	Terminal strength	A static load of 5N (510gf) shall be applied to the terminal for 10 sec. Terminals shall be inclined through an angle of 45° in the vertical plane and then returned to its initial position . This cycle shall be made for twice	Without excessive looseness of terminals
4	Shaft load	A load of 1 N shall be applied perpendicular to the shaft for 10s.	Clauses 3-1-1 and 3-1-2 should be satisfied

#### 3-2 Electrical characteristics:

	Items	Conditions	Specification
1	Rated voltage		100 V d.c.
2	Nominal capacitance	Maximum capacitance(Measured at 1MHz)	Table 1 shall be satisfied.
		Minimum capacitance(Measured at 1MHz)	Table 1 shall be satisfied.

	Items	Conditions	Specifications														
3	Q	Measured at 1MHz, Cmax	Table 1 shall be satisfied.														
4	Insulation resistance	A voltage of 100 V d.c. shall be applied for 1 min, after which measurement shall be made	10000 M or more														
5	Dielectric strength	100 V d.c. for 1 min	Without damage														
6	Capacitance drift after adjustment	Rotation shall be made for 1 cycles for 180 degree at a rate of 20 rpm. Difference between the capacitance value immediately after the shaft is stopped at the position of the maximum capacitance value and the value after 1.5min later.(measured at 1 MHZ)	± 1% within														
7	Temperature characteristics and change in capacitance	Test condition : Capacitance shall be 80% to 90% of the maximum value. <table border="1" data-bbox="571 992 1118 1339"> <thead> <tr> <th>Step</th> <th>Temperature</th> <th>Duration</th> </tr> </thead> <tbody> <tr> <td>1</td> <td>20 ± 2</td> <td rowspan="5">60min</td> </tr> <tr> <td>2</td> <td>-25 ± 3</td> </tr> <tr> <td>3</td> <td>20 ± 2</td> </tr> <tr> <td>4</td> <td>85 ± 2</td> </tr> <tr> <td>5</td> <td>20 ± 2</td> </tr> </tbody> </table> <p><b>Temperature coefficient</b>  <math display="block">=(C2-C1)/C1(T2-T1)X10^6(\text{ppm/ } )</math>                     however:                      C1= capacitance at step3                      C2= capacitance at step2/or step4                      T1= measuring temperature at step3                      T2= measuring temperature at step2/or step4</p>	Step	Temperature	Duration	1	20 ± 2	60min	2	-25 ± 3	3	20 ± 2	4	85 ± 2	5	20 ± 2	Table 1 shall be satisfied
Step	Temperature	Duration															
1	20 ± 2	60min															
2	-25 ± 3																
3	20 ± 2																
4	85 ± 2																
5	20 ± 2																
		<p><b>Change in capacitance</b>                      For difference of maximum capacitance at steps 1,3 or 5, refer to the value at step 3</p>	5% within														

**3-3 Endurance characteristics:**

Test capacity shall be 80% to 90% of the maximum value excluding clauses 3-3-1, 3-3-3 and 3-3-10.

	Items	Conditions	Specification
1	Solder ability	Bit temperature : $390 \pm 10$  Application time of solder iron : 3sec or less	(1)Solder wetting time shall be 3 s or less.  (2)A new uniform coating of solder shall cover a minimum of 95% of the surface being immersed.
2	Resistance to soldering heat	<u>Solder bath method</u> Solder temperature : $260 \pm 5$ Immersion time : $7 \pm 0.5$ sec Immersion dept : up to the surface of the board. <u>Solder iron method</u> Bit temperature : $390 \pm 10$ Application time of solder iron : $3 \pm 0.5$ sec	Table 2 shall be satisfied.
3	Resistance to flux penetration	The printed wiring board shall be fully immersed in the flux for 3 to 5 s and then taken out of the flux . the capacitor shall be inserted completely into the board as soon as the board is removed from the flux . either the flux bath method or the foaming method shall be used to apply flux to the board . in either case , flux should not come into contact with the component side surface and fluxing time shall be 3 to 4 s.  Note :after fluxing , if preheating is necessary before mounting ,then the surface of the solder side shall be heated to 75 to 90 for 1 min or less.  Using an automatic soldering system or a hand dipping system. The board shall be soldered up the component side surface (but the solder shall not come into contact with the component side )for $5 \pm 1$ s at 250 to 260 ,the board shall be subjected to standard atmospheric conditions for 24 h or more after the soldering .tests shall then be carried out as specified below.  visual inspection of appearance . measurement of characteristics as specified.	Electrical characteristics and mechanical characteristics shall be satisfied.
4	Vibration	At maximum capacitance , only endurance conditioning by a frequency shall be made .the entire frequency range , from 10Hz to 50Hz and return to 10Hz , shall be transverse in 1 min.  Amplitude (total excursion) : 1.5 mm  This motion shall be applied for a period of 2 h in each of mutually perpendicular axis (a total of 6 h)  The variable capacitance shall be subjected to standard atmospheric for other procedures.	Table 2 shall be satisfied.
5	Shock	At maximum capacitance. Peak acceleration : $490 \text{ m/s}^2$ (50G) Duration of pulse : 11 ms Three successive shall be applied in both directions of mutually perpendicular axis (a total of 18 shock).	Table 2 shall be satisfied.

	Items	Conditions	Specification															
6	Cold	Placed in tank at $-25 \pm 2$ for $48 \pm 4$ hours, left at room temperature for 1 hour after which measurement shall be made.	Table 2 shall be satisfied.															
7	Dry heat	Placed in tank at $85 \pm 2$ for $48 \pm 4$ hours, left at room temperature for 1 hour after which measurement shall be made.	Table 2 shall be satisfied.															
8	Damp heat	Placed in tank at $40 \pm 2$ , 90% to 95%RH for $96 \pm 4$ hours, left at room temperature for 1 hour after which measurement shall be made.	Table 2 shall be satisfied.															
9	Change of temperature	<p>The capacitor shall be subject to 5 continuous cycles, such as shown in table below . And then it shall be subjected to the controlled recovery conditions for 1 hour, after which measurement shall be made.</p> <table border="1"> <thead> <tr> <th>Step</th> <th>Temperature</th> <th>Duration(min)</th> </tr> </thead> <tbody> <tr> <td>1</td> <td><math>-25 \pm 3</math></td> <td>30</td> </tr> <tr> <td>2</td> <td><math>20 \pm 2</math></td> <td>10~15</td> </tr> <tr> <td>3</td> <td><math>85 \pm 2</math></td> <td>30</td> </tr> <tr> <td>4</td> <td><math>20 \pm 2</math></td> <td>10~15</td> </tr> </tbody> </table>	Step	Temperature	Duration(min)	1	$-25 \pm 3$	30	2	$20 \pm 2$	10~15	3	$85 \pm 2$	30	4	$20 \pm 2$	10~15	Table 2 shall be satisfied.
Step	Temperature	Duration(min)																
1	$-25 \pm 3$	30																
2	$20 \pm 2$	10~15																
3	$85 \pm 2$	30																
4	$20 \pm 2$	10~15																
10	Operating endurance	The capacitor shall be subject to 10 cycles(5 cycles for each left and right) at a speed of 10 rpm to 15rpm.	Table 2 shall be satisfied.															

Table 2

	Items	Conditions	Specification
1	Appearance		There shall be no deformation, excessive looseness, or damage
2	Rotational torque	Refer to clauses 3-1-1 and 3-1-2	Clauses 3-1-1 and 3-1-2 should be satisfied
3	Change in capacitance	Refer to clauses 3-2-2	Relative to previously ( $\pm 5\%$ ) within specified value
4	Q	Refer to clauses 3-2-3	Clauses 3-2-3 should be satisfied
5	Insulation resistance	Refer to clauses 3-2-4	Clauses 3-2-4 should be satisfied
6	Dielectric strength	Refer to clauses 3-2-5	Clauses 3-2-5 should be satisfied

Change in capacitance  $= (C2 - C1) / C1 \times 100(\%)$

C1=value measured before test

C2=value measured after test

#### 4. Marking

The following items shall be marked indelibly and legibly on the capacitor or on each unit pack.

4-1 Products name.

4-2 Type name or part number.

4-3 Month and year of or production code (including lot No.)

4-4 Manufacturer's name (abbreviated manufacturer's name permitted) or trademark.

4-5 Country of origin, china.

#### 5. Package

	Components	Materials	Supplier	Q'TY
1	Inner packaging	PE	Changde Zhengda Plastics Factory	10/500
2	Packaging case	Paper	Changde Jiehao Packing-Color Printing Co.,Ltd.	1/5000